

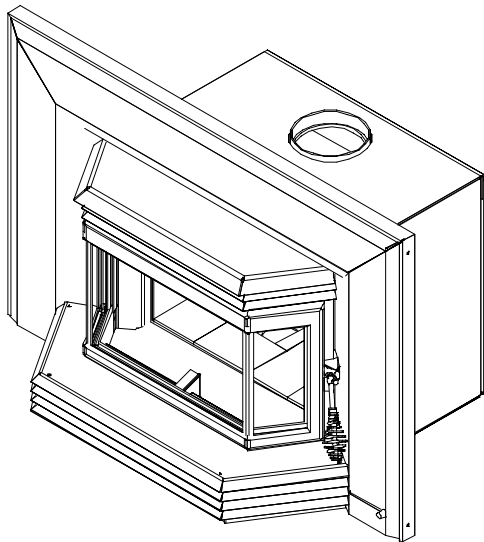

OWNER'S MANUAL

2200 MODEL INSERT



US ENVIRONMENTAL PROTECTION
AGENCY PHASE II CERTIFIED
WOOD INSERT

Verified and tested following
ULC S627 and UL 1482 Standards
by:



Manufactured by : **STOVE BUILDER INTERNATIONAL INC..**

1700, Léon-Harmel, Québec (Québec) G1N 4R9

Tel : (418) 527-3060

Fax : (418) 527-4311

www.osburn-mfg.com

READ AND KEEP THIS MANUAL FOR REFERENCE

INTRODUCTION

SBI INC., one of the most important wood stove and fireplace manufacturers in Canada, congratulates you on your purchase and wishes to help you get maximum satisfaction from your wood stove. In the pages that follow, we will give you advice on wood heating and controlled combustion as well as technical specifications regarding installation, operation and maintenance of the model you have chosen.

The instructions pertaining to the installation of your wood stove comply with ULC-S627 and UL-1482 standards.

Read this entire manual before you install and use your new stove. If this stove is not properly installed, a house fire may result. To reduce the risk of fire, follow the installation instructions. Failure to follow instructions may result in property damage, bodily injury, or even death.

Consult your municipal building department or fire officials about restrictions and installations requirements in your area and the need to obtain a permit.

Keep this instructions manual for future references.

CAUTIONS:

- HOT WHILE IN OPERATION. KEEP CHILDREN, CLOTHING AND FURNITURE AWAY. CONTACT MAY CAUSE SKIN BURNS.
- DO NOT USE CHEMICALS OR FLUIDS TO IGNITE THE FIRE.
- DO NOT LEAVE THE STOVE UNATTENDED WHEN THE DOOR IS SLIGHTLY OPENED.
- DO NOT BURN WASTES, FLAMMABLE FLUID SUCH AS GASOLINE, NAPHTHA OR MOTOR OIL.
- DO NOT CONNECT TO ANY AIR DISTRIBUTION DUCT OR SYSTEM.
- ALWAYS CLOSE THE DOOR AFTER THE IGNITION.

TABLE OF CONTENTS

INTRODUCTION.....	1
SECTION 1.0 PRE-INSTALLATION REQUIREMENTS	4
1.1 MASONRY & ZERO CLEARANCE REQUIREMENTS.....	4
1.2 VENTING REQUIREMENTS	5
SECTION 2.0 INSTALLATION	6
CLEARANCES TO COMBUSTIBLES (MEASURED FROM INSERT BODY)	6
2.1.1 HEARTH REQUIREMENTS	7
2.2 SUITABLE FIREPLACE DIMENSIONS	7
2.3 SAFETY INFORMATION.....	7
2.4 INSTALLATION INSTRUCTIONS.....	8
2.5 AIR CONTROL PLATE, FACEPLATE AND FAN ASSEMBLY INSTRUCTIONS.....	10
SECTION 3.0 OPERATION.....	13
3.1 SAFETY INFORMATION.....	13
3.2 FUEL	14
3.2.1 SIMPLE WOOD MOISTURE TEST	15
3.3 NOTES ABOUT FIRST FIRING.....	15
3.4 LIGHTING A FIRE	15
3.5 MAINTAINING THE FIRE	17
3.6 FAN OPERATION.....	17
SECTION 4.0 MAINTENANCE.....	18
4.1 CARE AND CLEANING	18
4.1.1 GLASS CLEANING.....	18
4.2 ASH REMOVAL.....	18
4.3 CHIMNEY CLEANING	18
4.4 BAFFLE INSTALLATION AND BRICK NOTES	19
4.5 SECONDARY AIR TUBE REPLACEMENT	21
4.6 FAN MAINTENANCE & CARE	22
SECTION 5.0 TROUBLESHOOTING.....	24
SECTION 6.0 SPECIFICATIONS.....	25
LIMITED LIFETIME WARRANTY	26

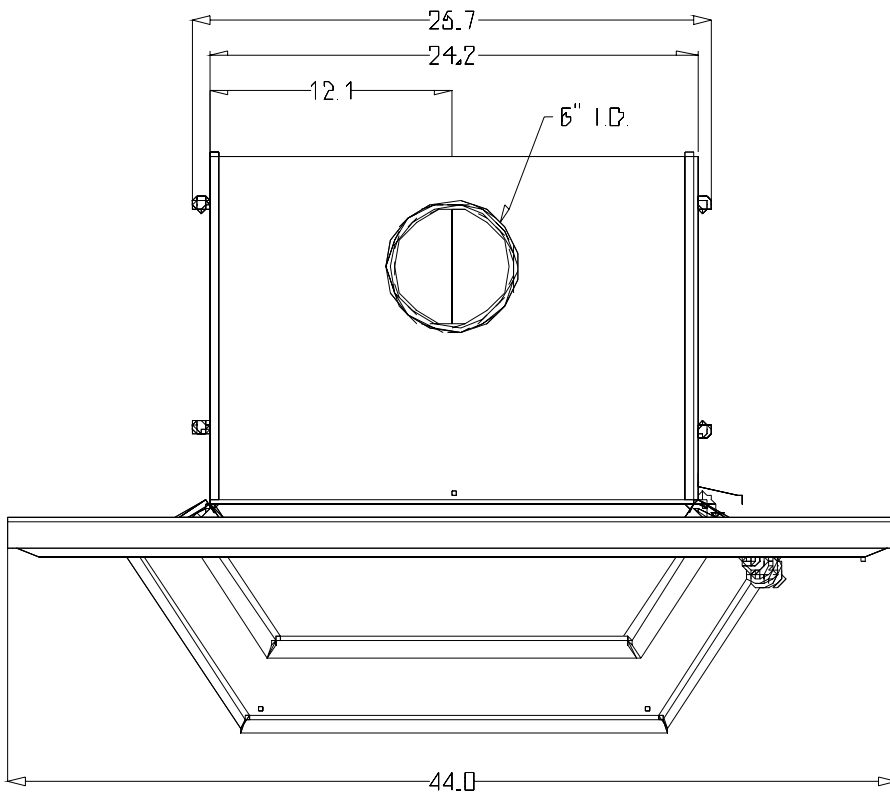
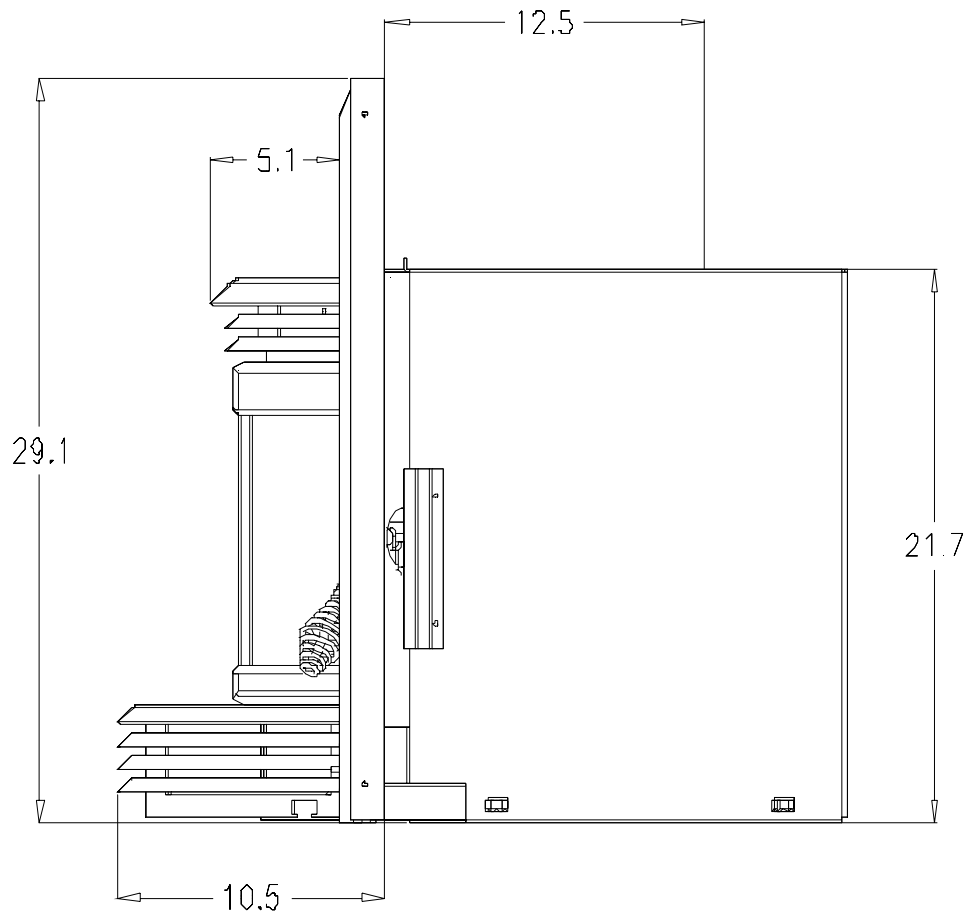

Section 1.0 Pre-Installation Requirements

1.1 Masonry & Zero Clearance Requirements

The masonry fireplace must meet the minimum code requirements, or NFPA 211 or the equivalent for a safe installation. Contact your local Building Inspector for requirements in your area. An inspection of the fireplace should include the following:

1. **CONDITION OF THE FIREPLACE AND CHIMNEY:** Examine the masonry fireplace and chimney prior to installation, to determine that they are free from cracks, loose mortar, creosote deposits, blockage, or other signs of deterioration. If evidence of deterioration is noted, the fireplace or chimney should be upgraded prior to installation.
2. **ZERO CLEARANCE OR METAL HEATFORM FIREPLACE:** These fireplaces and chimneys must meet the conditions above, and the factory built zero clearance fireplace must be listed. They must be suitable for use with solid fuel. The chimney must be at least 1" (25mm) larger in diameter to accommodate a required continuous stainless steel liner running from the flue collar to the top of the chimney termination.

Only readily detachable parts that are easily replaced, such as damper parts, screens, doors, and side and back refractory panels, are to be removed from the fireplace. These parts must be stored nearby and available for retrofit if the insert is ever removed. Removal of any parts which render the fireplace unfit for use with solid fuel requires the fireplace to be permanently labeled by the installer as being no longer suitable for solid fuel until the removed parts are replaced and the fireplace is restored to its original certified condition.

3. **CHIMNEY CAPS:** Mesh type chimney caps must have provision for regular cleaning, or the mesh should be removed to eliminate the potential of plugging.
4. **LINER:** The chimney must have an acceptable masonry liner suitable for solid fuel, otherwise a continuous stainless steel liner must be installed.
5. **ADJACENT COMBUSTIBLES:** The fireplace should be inspected to make sure that there is adequate clearance to combustibles, both exposed combustibles to the top, side, and front as well as concealed combustibles, in the chimney and mantel area. Your local inspector should have information on whether older fireplaces are of adequate construction.
6. **OPENING SIZE:** Refer to "*Suitable Fireplace Dimensions*" (Sec. 2.2) for suitable size fireplace openings.

NOTE: A METAL TAG IS PROVIDED AND IS TO BE FASTENED TO THE BACK WALL OF THE FIREPLACE, IF THE FIREPLACE HAS BEEN MODIFIED TO ACCOMMODATE THE INSERT.

1.2 Venting Requirements

The flue is a critical component to a satisfactory installation. Your Osburn insert will attain its best performance if installed with a chimney that generates its own draft. The minimum requirement of a flue will be the installation of a flue connector (the liner must conform to UL1777 chimney liners) from the insert into the first flue tile of the chimney (USA), see Figure 2.3 , or a continuous stainless steel liner (the liner must conform to the Class 3 requirements of CAN/ULC-S635) directly connected to the flue outlet (Canada), see Figure 2.2. A continuous 6" (152mm) stainless steel liner from the top of the chimney is the optimum system and will provide the best performance, as well as compensate for poor draft situations caused by large cross-sectional chimneys. The insert will not work without a positive seal in the chimney.

Chimneys constructed outside of the home, on an exterior wall, should be avoided if possible, especially in colder climates. Outside chimneys may not draw as well and may downdraft due to the difficulty in heating them up to operating temperature. Cooler chimneys will result in increased creosoteing, less draft, and poorer performance. Draft is proportional to overall chimney height as well as to stack temperature. Draft can be increased by increasing chimney height, and by reducing heat loss from the chimney through an insulated liner.

Ensure that all joints in the flue systems are tightly sealed, since any leaks will result in reduced performance as well as a possible safety hazard.

Section 2.0 Installation

Clearances To Combustibles (Measured From Insert Body)

	North American	Australia/New Zealand
Sidewall (A)	17" (432mm)	432mm
Top Facing (B)	14" (356mm)	356mm
Side Facing (C)	10" (254mm)	254mm
Mantel (D)	22" (559mm)	559mm

Table 2.1

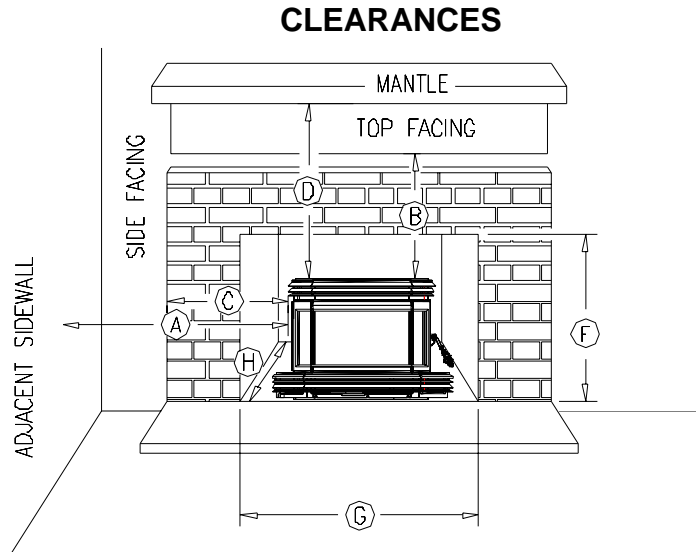

Figure 2.1

Note: If side facing protrudes more than 1.5" (38mm) in front of face of fireplace, then use sidewall clearance.

2.1.1 Hearth Requirements

If the non-combustible hearth is flush with the floor, then the hearth must be 16" (406mm) in front of the fan housing (see Figure 2.1.2). If the non-combustible hearth is a minimum of 4" (102mm) above the floor, then the hearth can be 6" (152mm) out from the fan housing with a 10" (254mm) floor protection (sparks) extended beyond the hearth (see Figure 2.1.1). The non-combustible hearth must be a minimum of 8" (203mm) on each side of the unit (Canada & US) or 200mm for Australia as measured from the load door.

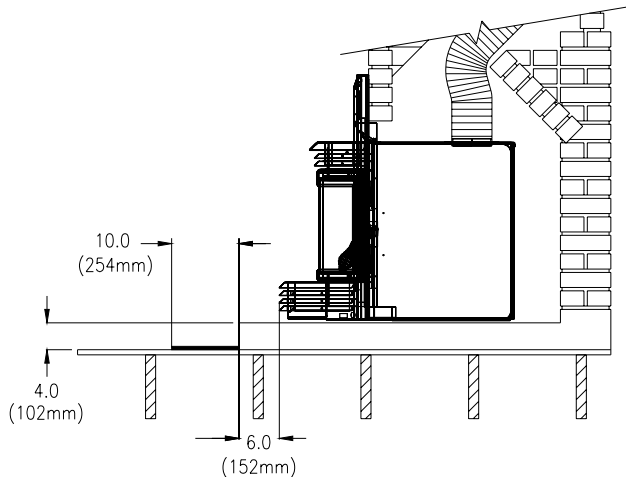

Figure 2.1.1

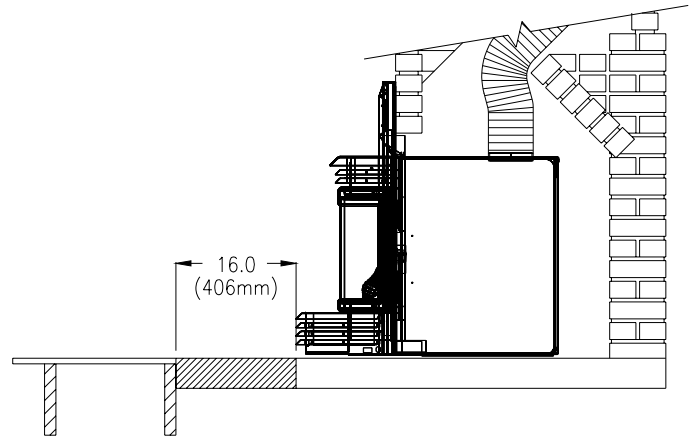

Figure 2.1.2

2.2 Suitable Fireplace Dimensions

MEASUREMENT FOR	MINIMUM
Opening Height (F)	21.75" (553mm)
Opening Width (G)	28" (711mm)
Opening Depth (H)	17.8" (452mm)

Table 2.2

2.3 Safety Information

NOTE: This appliance is not recommended for use in a home if an occupant has any respiratory or any other related problems.

1. It is important to follow the installation and operation instructions. An improperly installed or operated insert could result in a safety hazard or fire, or damage to the unit, which would not be covered by the warranty. Contact local building or fire officials about restrictions and installation requirements in your area. You should be familiar with the installation and be sure that the work is

done in accordance with this manual.

WARNING: DO NOT INSTALL THIS INSERT IN A SLEEPING ROOM.

2. Where lesser clearances are desired, consult your local authority as regulations may vary regarding the use of clearance reducing devices. Listed wall and floor shields are available to reduce clearances, and most building codes provide information on materials which may be used to reduce clearances (see Figure 1).
3. Maintain at least the minimum clearances to combustible material as specified in this manual. Clearances are measured to the nearest part of the insert (i.e. top edge on the side). Clearances to any combustibles, when measured directly out from the front, must be a minimum of 48" (1219mm).
4. Maintain at least the minimum floor protection for combustible floor materials as specified in this manual. Floor protection to the front is to be measured from the fuel loading door opening.
5. Osburn recommends that you install a listed smoke detector or alarm in your home. Normal operation of the insert will have no effect on the detector or alarm.
6. The insert is to be connected only to a lined masonry chimney and masonry fireplace conforming to building codes for use with solid fuel. Do not remove bricks or mortar from the existing fireplace when installing the insert.
7. Minimum chimney size is 6" (152mm) diameter. Maintain a 15' (4.5m) minimum overall height measured from the base of the appliance. Chimneys should be inspected to check for deterioration and to determine if they meet the minimum requirements, and be upgraded if necessary. The chimney must extend at least 3' (914mm) above the roof and at least 2' (610mm) above the highest point within an area of 10' (3m) of the chimney.
8. Do not use makeshift compromises during installation, as they could create a safety hazard and a fire could result.
9. ***DO NOT CONNECT THIS APPLIANCE TO THE CHIMNEY OR FLUE SERVING ANOTHER APPLIANCE.***

2.4 Installation Instructions

1. Inspect the fireplace according to the safety information and fireplace requirements and have it cleaned and/or upgraded as necessary.
2. If the installation of the unit renders the existing damper control inaccessible, it will be necessary to either secure the damper wide open or remove it entirely. An inaccessible damper, which may close, could cause smoke to enter the room. This creates a potential health hazard.
3. ***CONNECTOR INSTALLATION:*** A flue connector may provide acceptable performance, however, we recommend the use of a chimney liner to ensure satisfactory performance. Slip connectors for continuous liners should also be installed. Use Listed Chimney Liners – UL1777, CAN/ULC-S635.
4. ***ATTENTION INSTALLER:*** When positioning the unit in a fireplace opening prior to the flue

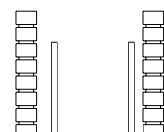
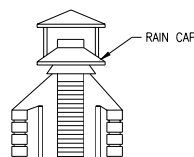

installation, install the insert into the opening until the top lip of air jacket is flush with fireplace facing.

Figure 2.2

Figure 2.3

4. If lag-bolts and anchors are to be used to secure the insert, the hole locations should be marked with the unit in place. Remove the insert and locate the anchors.
5. Remove the faceplate panels from their box and assemble according to the following instructions.

2.5 Air control plate, faceplate and fan Assembly Instructions

1. Place the faceplate panels with the finished side down on a flat, soft, non-abrasive surface.
2. Assemble the faceplate trim, attaching the mitered corners with the corner brackets. (see Figure 2.5)
3. Line up the holes of the side and top panels and secure with the six (6) screws, washers and nuts. (see Figure 2.6)
4. Slide the assembled trim over the edges of the faceplate.
5. Secure trim to faceplate using four (4) brass screws and nuts. (see Figure 2.6)
6. Locate air control plate Fig 2.4.1 (shipped inside firebox). Slide air control into tracks on firebox bottom as indicated in Fig 2.4.2.
7. Attach air control plate extension as shown in Fig 2.4.3 and 2.4.4 using $\frac{1}{4}$ x 1 hex cap screws (also shipped in the firebox).

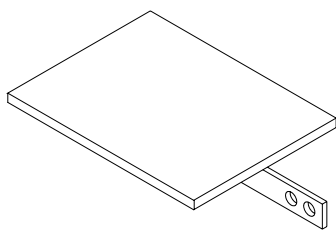

Figure 2.4.1

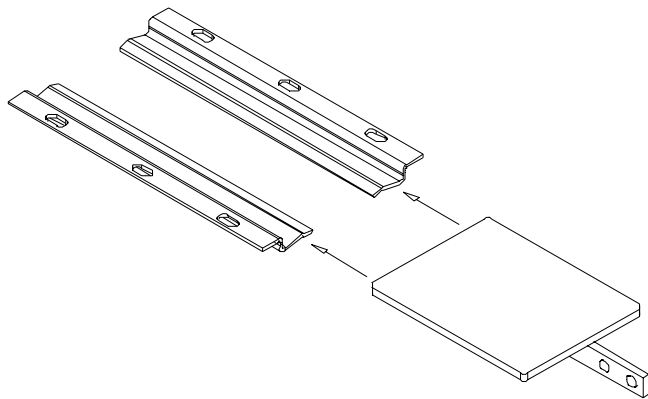

Figure 2.4.2

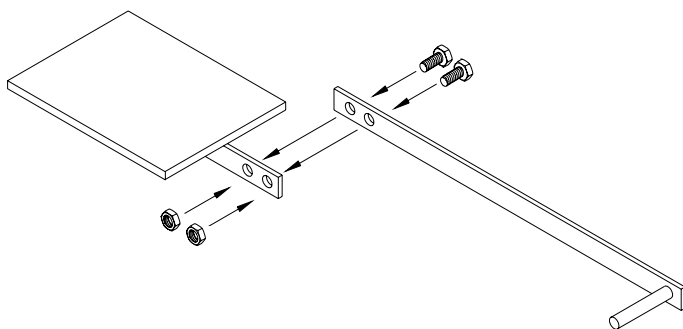

Figure 2.4.3

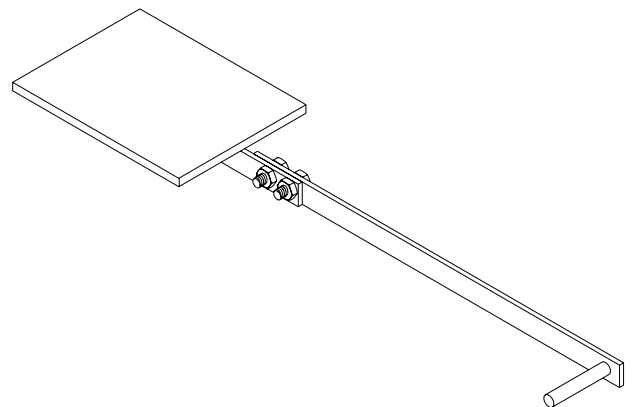

Figure 2.4.4

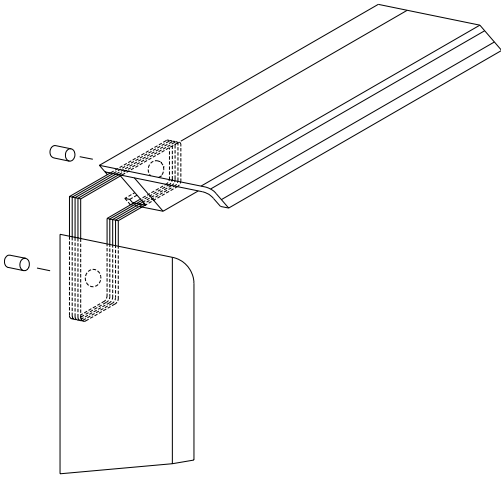

Figure 2.5

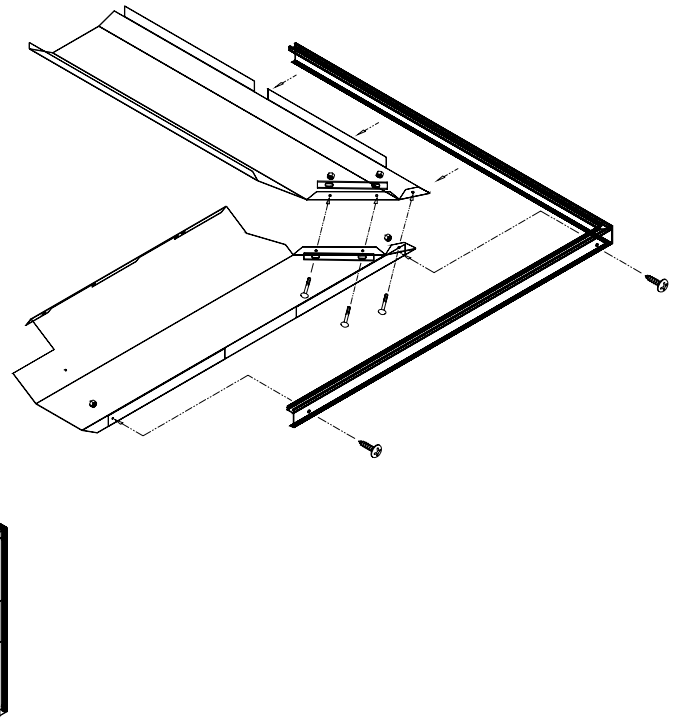

Figure 2.6

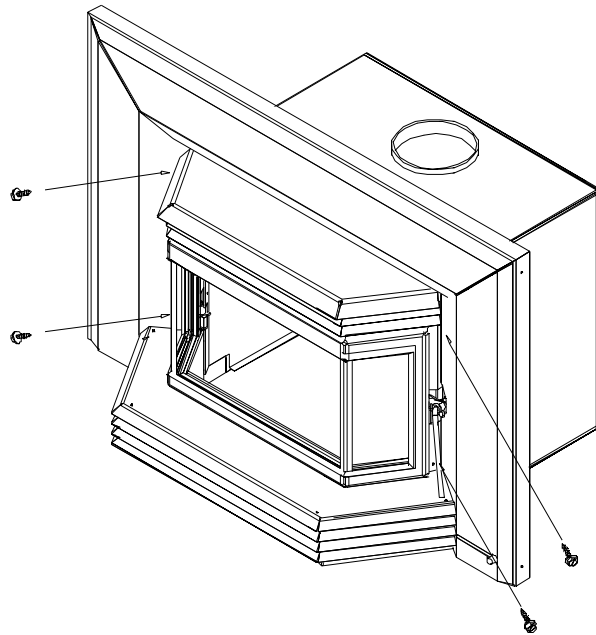

Figure 2.7

8. Fan is already attached to the unit at the factory with two tie straps to reattach fan to unit see (Figure 2.7)

9. Cooktop is installed at the factory, Shipping screw must be removed before installation of faceplates. (Figure 2.8)
10. Install faceplate (Figure 2.7) with four HF47 (#10 x 3/8" sheet metal) screws supplied, ensuring the 1/4" rod on the air control plate extension protrudes through the slot in the RH faceplate & moves freely horizontally.
11. Add the HM95 air control knob (Figure 2.10).

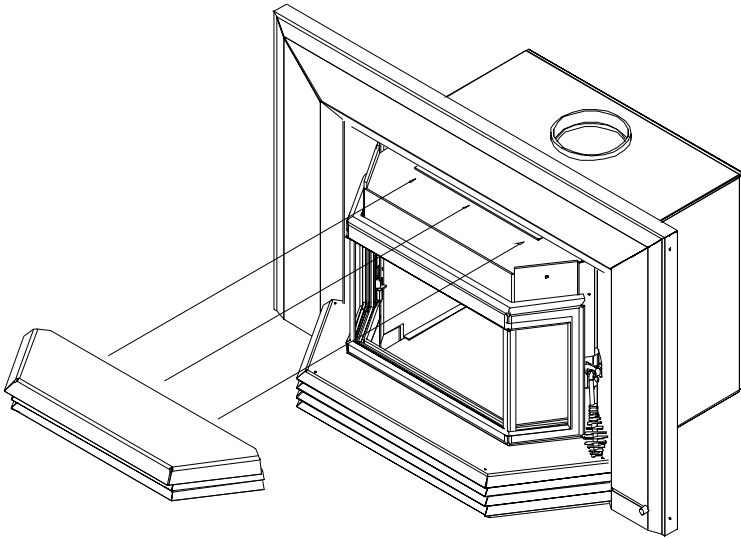

Figure 2.8

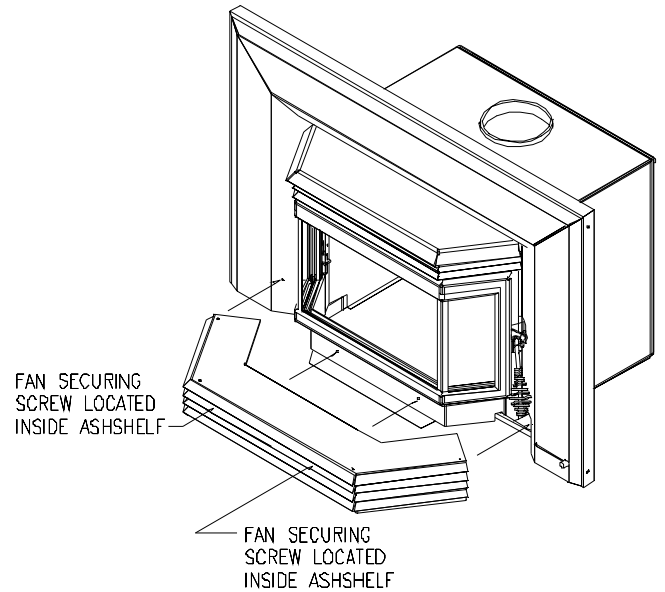

Figure 2.9

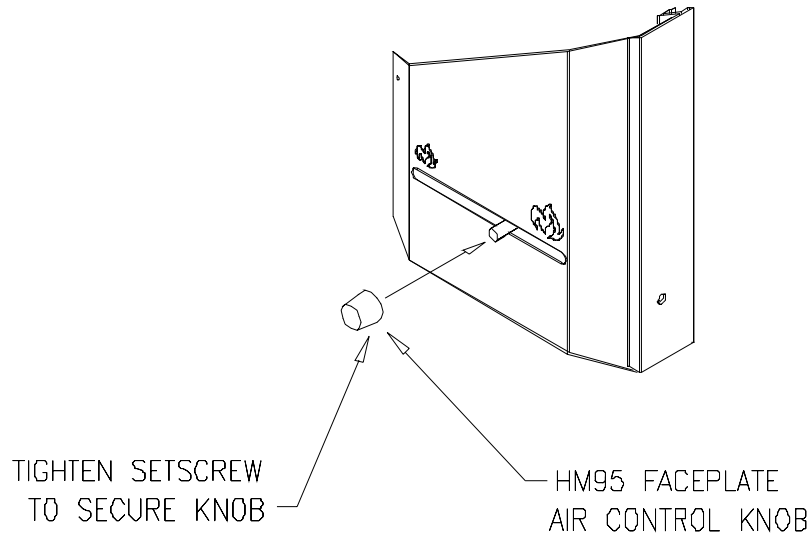

Figure 2.10

Section 3.0 Operation

3.1 Safety Information

1. This insert is designed for safe operation *WHEN BURNING CORDWOOD ONLY*. Altering or modifying the unit or the installation without proper authorization will void the certification, warranty, and safety listing, and may result in a safety hazard.
2. For safety reasons, never leave the unit unattended with the door open or ajar. An open door, and especially a door partially open or cracked, if left for longer than required for good ignition can potentially result in unsafe chimney temperatures, and if left unattended, hot embers or ignited fuel may fall out of the unit. Prolonged door open operation is not necessary provided the unit has been properly installed and dry kindling is used to start the fire.
3. Do not abuse the unit, either by over firing or by using wood or combustibles with salt content, or harmful chemicals. Misuse is not covered by warranty.
4. Even though your Osburn has been specifically designed and tested to prevent smoke spillage, always open the door slowly as this will minimize the likelihood of smoke spillage or a back draft causing flame or smoke to spill into the room.
5. Never use gasoline type lantern fuel, kerosene, solvents, charcoal lighter fluid, or inflammable liquids to start or "freshen" a fire in the insert. Keep all such liquids well away from the insert while it is in use.
6. All insert surfaces become very hot during operation. Care is needed, especially with children, to avoid contacting these surfaces.
7. Do not elevate the fire by means of grates, and irons or other means.
8. **CAUTION: DO NOT OVER FIRE THIS HEATER.** Do not burn fuel in the insert at a rate higher than that which will cause the ember bed level to exceed half the door opening height. If burning hot fires regularly, purchase an insert top thermometer, and do not exceed 840° F (450° C) as measured on the Cooktop. If the door handle of the insert becomes excessively hot to the touch, consider this to be an indication of over firing. Over firing can result in a safety hazard and can permanently damage the insert and chimney. This damage is not covered by the warranty.
9. Although the ceramic glass is extremely durable under any normal use, a few precautions are required. Do not attempt to push logs further into the fire by using the door, as the glass may break if it is heavily contacted by any solid object.

10. Never operate the insert with the door open, or cracked slightly open, except briefly during the lighting operation, and during refuelling. Leaving the door open continuously could seriously overheat the chimney and adjacent combustibles. Do not operate the insert if there is an abnormal air leakage into the unit, such as through deteriorated gaskets or cracked or broken glass. Do not operate the insert without a door gasket. Leakage can result in overheating, or in very airtight homes, could possibly cause smoke spillage into the room. Smoke may contain carbon monoxide, which is poisonous, and in sufficient quantities is a health hazard.
11. We recommend that you have a fresh air or make up air supply for the insert. In Canada this is a building code requirement. If this is not done, it could cause poor air quality in the home, poor and incomplete combustion, and poor efficiency in the insert.

3.2 Fuel

1. Fuel for the insert must not be stored closer than the required clearances to combustibles and not in the space required for ash removal.
2. Your Osburn insert is designed to burn *CORDWOOD FUEL ONLY*. Do not burn coal, charcoal, or trash in the unit. Highly flammable items such as trash may ignite creosote in the chimney, resulting in a chimney fire. Never burn salt wood, beachwood, chemically treated wood, or wood removed from salt water, since the deposits left will deteriorate the firebox. Damage caused by chemicals or salt is not covered under warranty.
3. Seasoned dense wood is recommended. Wood should be air dried in a covered ventilated area for six months to a year or more. This reduces the moisture content of the wood, resulting in better insert performance. Wood species with a moisture content of 20% or less are ideal. Dry seasoned wood can be distinguished from green wood by the checks or cracks in the ends.
4. Wet or green wood will tend to cause the fire to smoulder, producing large amounts of creosote. Creosote build-up could result in a chimney fire. This wood will also prove difficult to keep burning properly, and fires will tend to go out. Green wood produces very little heat, and sometimes causes customers to think that the insert does not work. If you must burn wet wood, use only small amounts mixed with dry wood.
5. Decayed wood or low density wood has very little energy content or heating value, and will not burn satisfactorily for long periods of time.

An example of the energy values of some common wood fuels is given in Table 3.1
For recommended wood sizes, refer to the specifications.

Common Heating Values of Cordwood

Hardwoods	Million Btu/Cord	Softwoods	Million Btu/Cord
Birch	23.6	Douglas Fir	20.6
White Oak	28.3	Hemlock	17.1
Alder	17.6	Jack Pine	18.4

Table 3.1

3.2.1 Simple Wood Moisture Test

Add one large piece of wood to the top of an established fire. If it starts to burn on three sides within one minute, it is dry and seasoned and right for burning. If it turns black and starts to burn in three minutes, it is damp. If it turns black and does not start burning until after five minutes, it is green and wet. If it hisses at any time the wood is soaked and will not burn until excess moisture is boiled away.

3.3 Notes About First Firing

Before firing ensure that the room is well ventilated.

Curing the paint is recommended to preserve the best quality finish. Heating the insert too intensely on the first fire will dull and lighten the colour on overheated areas, and cause smoke and odour to be emitted into the room. To cure the paint, the first two fires should be burned for only about twenty minutes each.

Allow the insert to get warm only, but not hot, i.e. 250° F (120° C) as measured by an insert top thermometer, then allow the insert to cool down. Light a third fire and burn it for about forty minutes to 450° F (230° C) or less. Once again cool the insert to room temperature, then operate it according to the following instructions. This extra care will result in a more durable, and uniform finish.

3.4 Lighting A Fire

1. Place enough crumpled balls of newspaper or other paper into the insert to cover the bottom of the firebox.
2. Place small dry kindling on the crumpled paper.
3. Place larger dry kindling on top of the small kindling.
4. Open the draft control fully to the right (located on the right side of the faceplate, Figure 3.1)
5. Light a fire at the bottom of the crumpled paper and close the door. If the fire tends to go out, momentarily hold the door slightly ajar to fan the fire. As soon as the fire catches hold, close the door.

6. Ideally the large kindling should be burned until a thick bed of red embers is obtained. At that point, add cordwood fuel and continue to operate the draft control wide open until the fire is well established. Once the firebox is hot, the draft control can be partially closed by moving the knob to the left to adjust the intensity of the fire.

Use Table 3.2 to adjust the draft control to the desired burn rate:

Draft Settings

Burn Rate	Draft Setting
Low	Move Control left to end of travel.
Medium Low	Move Control right by 9/16" - 1" (14.3 – 25.4mm) from closed position.
Medium High	Move Control right by 7/8" - 1 3/4" (22.2 – 44.5mm) from closed position
High	Move Control to right hand end of travel.

Table 3.2

Closing the draft control down too soon will lower combustion efficiency, and may result in creosote build-up in the chimney (which could lead to a future chimney fire).

CAUTION: THE ADJUSTMENT RANGE SHOULD NOT BE ALTERED FOR INCREASED FIRING FOR ANY REASON.

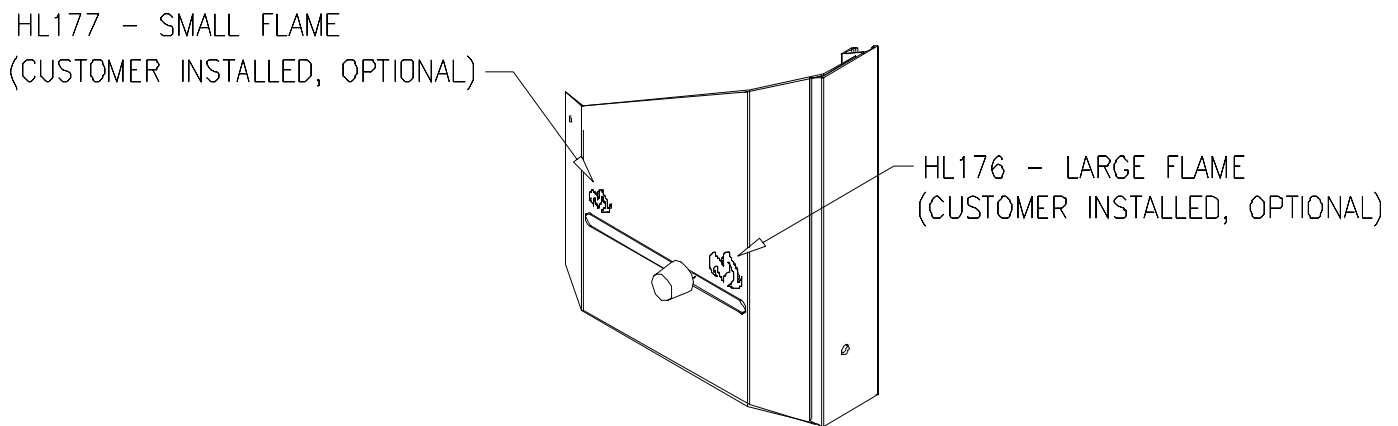

Figure 3.1

3.5 Maintaining The Fire

Your Osburn insert will work best if a thick bed of hot embers is maintained in the bottom of the firebox, and a minimum of two large pieces of seasoned fuel are added. Combustion efficiency is largely related to establishing a hot ember bed, and hot firebox temperatures. The quicker the insert and fuel get up to operating temperature, the better. A small intense fire is preferred to a large smouldering fire, both to improve combustion efficiency and to reduce the amount of creosote emitted.

The best performance will be achieved by adding relatively small amounts of fuel to a well established ember bed, and then operating with the air inlet control open long enough to achieve a hot fire. Cordwood should be placed with air in between individual pieces. Use a poker to make an air channel in the embers below the wood, this will allow air to flow under the wood for a more efficient burn.

Extended burn times can be accomplished by first operating the insert on a full load with the air inlet controls wide open. Once the fire is well established, and the moisture has been driven out of the wood, reduce the air control to a lower setting. The unit should then burn cleanly without smouldering. If the fire smoulders without flame, re-establish a hotter fire before moving the air control to the lower setting. A yellow flame burning in the top of the firebox is a good indication of a clean efficiently burning fire.

Refuelling technique is important for good performance. The best efficiency and performance from your insert can be achieved by adding partial loads of fuel and allowing them to get up to operating temperature before adding additional fuel. Adding a large amount of fuel at one time will increase the time required to get the fuel up to its ignition temperature, and an extended time to reach optimal performance. When refuelling, open the air control or hold the door partially open 1” (25 mm) or less, long enough (less than 5 minutes) so that the fire has well established flames. When refuelling, care is required to ensure that fuel or embers do not fall out of the door opening. The unit will burn at about 2.0 to 2.5 lb/hr (.9 to 1.1kg/hr) at its minimum setting; approximately 20 to 25 lbs (9 to 11.3kg) of wood are required for an extended burn.

3.6 Fan Operation

1. Allow the insert to reach operating temperature (approximately one hour), before turning on the fan, since increased airflow from the fan will remove heat and affect the start-up combustion efficiency.

NOTE: ENSURE THE FAN CORD IS NOT IN CONTACT WITH ANY SURFACE OF THE INSERT TO PREVENT ELECTRICAL SHOCK OR FIRE DAMAGE. DO NOT RUN CORD BENEATH THE INSERT.

2. Turn the fan on or off with the variable speed control located on the left side of the fan assembly below the bottom louvre. The switch settings are Off, High and adjustable down to Low.

Section 4.0 Maintenance

4.1 Care And Cleaning

Clean the insert frequently so that soot, ash and creosote do not accumulate. Do not attempt to clean the insert, glass or door when the unit is hot. Special care must be taken with Gold surfaces in order to maintain the finish at its original brilliance. Do not use an abrasive glass cleaner which will scratch the glass or gold finish. Use only a soft clean damp cloth on the door, since some cleaners may remove the plating or paint.

4.1.1 Glass Cleaning

Under normal operation the stove is designed to keep the glass clean. Glass cleaning may be required when burning damp wood and/or when burning slow fires. Generally if the glass is not staying clean then the unit is being under fired. Dirty glass may be self-cleaned by burning a hot fire (i.e. dry wood and opened draft controls) for a couple of hours. Good burning techniques will result in clean glass.

Hand clean the glass only when the fire is out and the insert is cold. A light film can usually be cleaned with paper towel and water. If heavy cleaning is required, a ceramic glass cleaner or polish is recommended, and should be rinsed off with water for best results.

4.2 Ash Removal

CAUTION: *Ashes can start fires, even after several days of inactivity. Never dispose of ashes in a combustible container. Remove ashes only when the insert and ashes are cold.*

Ashes should be removed from the insert frequently. When ashes are removed, they should be placed in a metal container with a tightly fitting lid. The closed container of ashes should be placed on a non-combustible floor or on the ground, well away from all combustible materials, pending final disposal. If the ashes are disposed of by burial in soil or otherwise locally dispersed, they should be retained in the closed container until all cinders have thoroughly cooled. Do not place other waste materials in the metal ash container.

4.3 Chimney Cleaning

Regular chimney maintenance, as well as good burning practices, are required to prevent chimney fires. The chimney and the chimney connector pipe must be maintained in good condition and be kept clean for optimal safety. The chimney should be checked regularly for creosote build-up. Inspection and cleaning of the chimney can be facilitated by removing the baffle.

CAUTION: OPERATION OF YOUR OSBURN 2200 WITHOUT THE BAFFLE MAY CAUSE UNSAFE AND HAZARDOUS TEMPERATURE CONDITIONS AND WILL VOID THE WARRANTY.

Contact your local, municipal, state, or provincial fire authority for information on how to handle a chimney fire before there is any chance that it may happen.

Creosote – Formation And Need For Removal

When wood (especially green wood) is burned without adequate heat or air supply, it produces tar and other organic vapours (*smoke*), which combine with expelled moisture to form creosote.

The creosote vapours condense in the relatively cool chimney flue of a slow-burning fire. As a result, creosote residue accumulates on the flue lining. When ignited, this creosote makes an extremely hot fire, which could be hazardous. Check frequently for creosote build-up. In the event of a insert or chimney component failure, replace only with equipment that is equivalent to the original, available from your Osburn dealer.

Your Osburn insert has been designed to reduce the amount of creosote produced. Even so, the chimney connector pipe and chimney should be inspected at least once every two months during the heating season to determine if a creosote build-up has occurred. If creosote has accumulated, it should be removed to reduce the risk of chimney fire. Call a professional chimney sweep, or go to your local Osburn dealer and purchase a chimney brush, and have the chimney cleaned.

4.4 Baffle Installation and Brick Notes

(see Figure 4.1)

1. The following items are shipped inside the firebox: five full bricks, five cut bricks, rear baffle support, front baffle support and stainless steel air tube c/w cotter pin, and two baffle boards.
2. Install rear baffle support, locating on baffle support tabs welded to side plenums.
3. Install five cut bricks starting with outermost bricks first (4" dimension goes front to rear). Push rear baffle support towards rear of firebox.
4. Install baffle boards above secondary air tubes.
5. Install front baffle support/extension, ensuring extension fits between front risers.
6. Install five full bricks, starting with outermost bricks first. See Figure 4.1.
7. Ensure baffle boards are located as per Figure 4.1.
8. Install secondary air tube ensuring air holes face forward. Install cotter pin as per Figure 4.3.
9. Remove in reverse order.

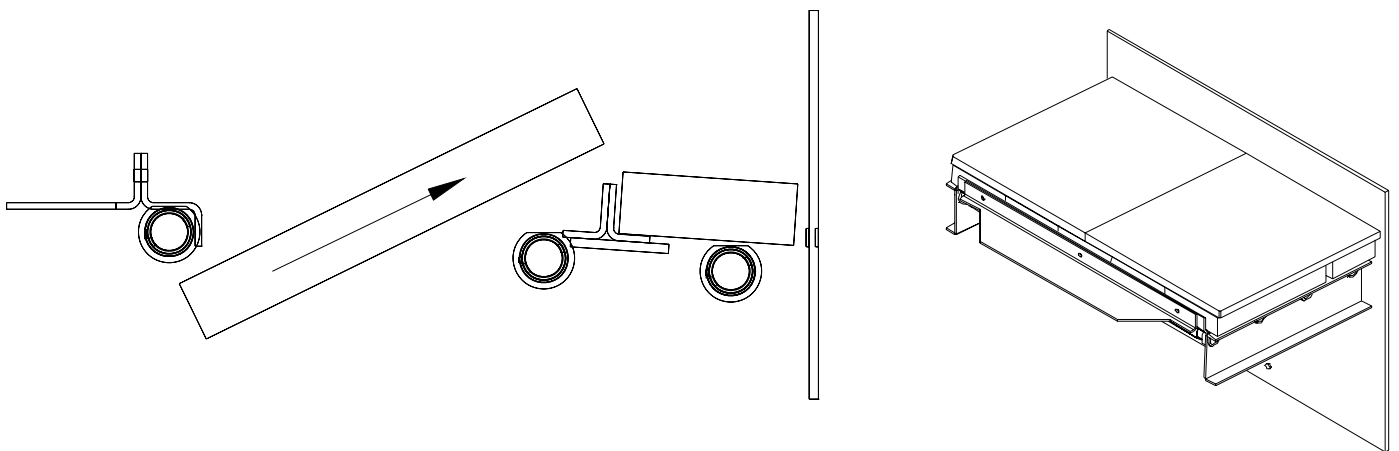
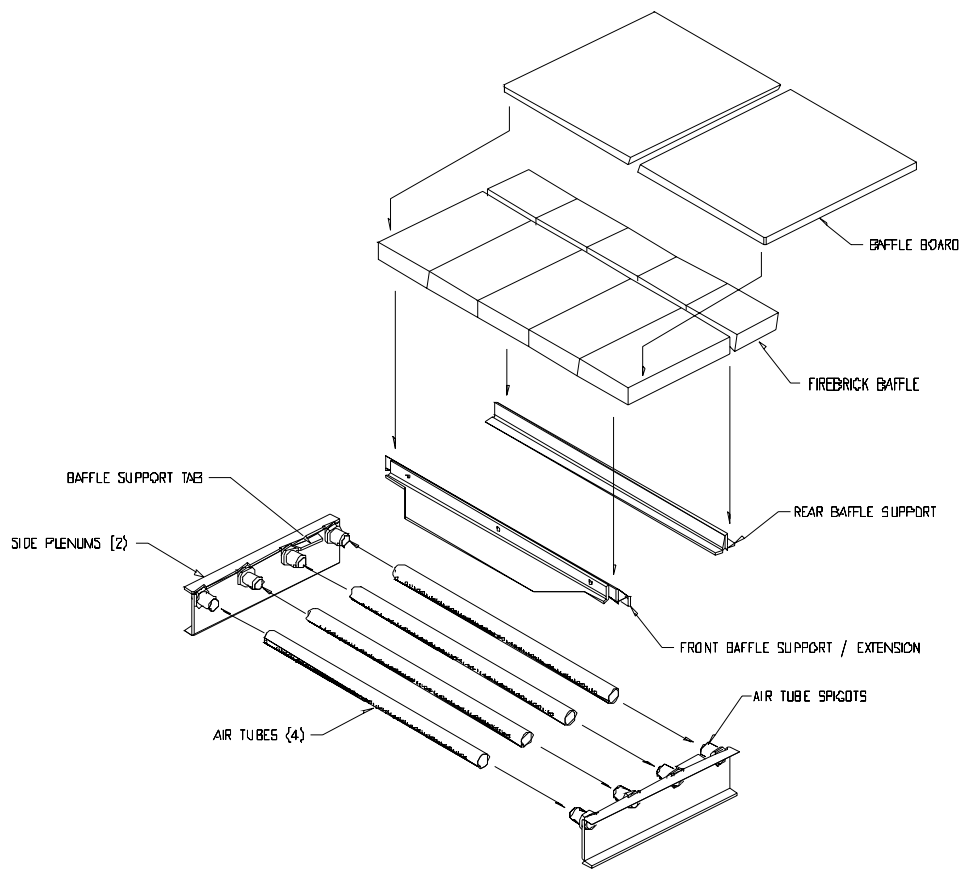
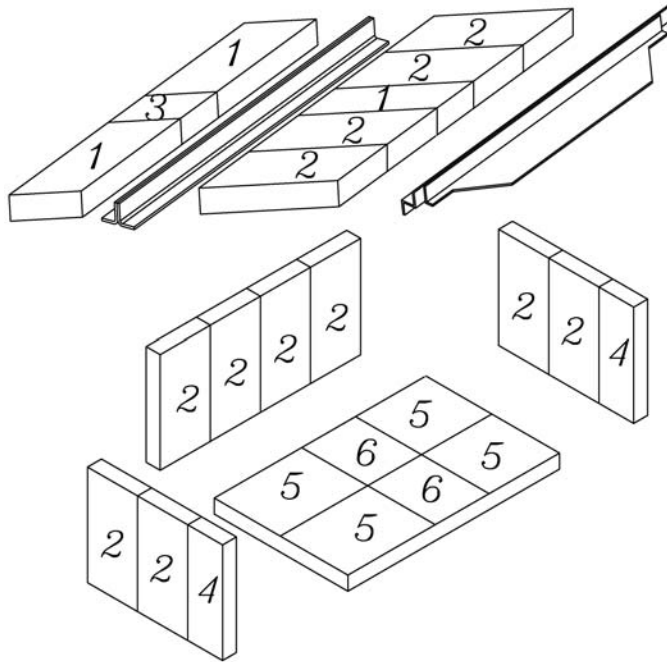

Figure 4.1 – Baffle installation & removal

All firebrick and duraboard baffles must be properly in place for correct burning operation. Have any damaged firebricks replaced. Check the firebricks annually for damage and replace if they are broken or damaged. See Figure 3.3 for the firebrick layout. Install the side & back firebricks first, and then the bottom firebricks.



①	1 1/4" X 4" X 9"	QTY:3
②	1 1/4" X 4 1/2" X 9"	QTY:12
③	1 1/4" X 4" X 4"	QTY:1
④	1 1/4" X 3 1/8" X 9"	QTY:2
⑤	1 1/4" X 6" X 8"	QTY:4
⑥	1 1/4" X 2 5/8" X 6"	QTY:2

4.5 Secondary Air Tube Replacement

(see Figure 4.3)

1. Remove cotter pin at LH end of tube.
2. Slide tube to right and lower tube end below LH plenum.
3. Slide tube to left to remove.
4. Reassemble in reverse order using a new cotter pin. The cotter pin is a hammerlock style and locks into place by hitting the head sharply with a hammer.
5. Note that any tube can be replaced without disturbing the baffle.

Important Notes:

The air tubes are identified for placement as follows:

- Front to back:
- Tube No. 1 67 Holes of .156" diameter
 - Tube No. 2 67 Holes of .140" diameter
 - Tube No. 3 67 Holes of .140" diameter
 - Tube No. 4 67 Holes of .125" diameter

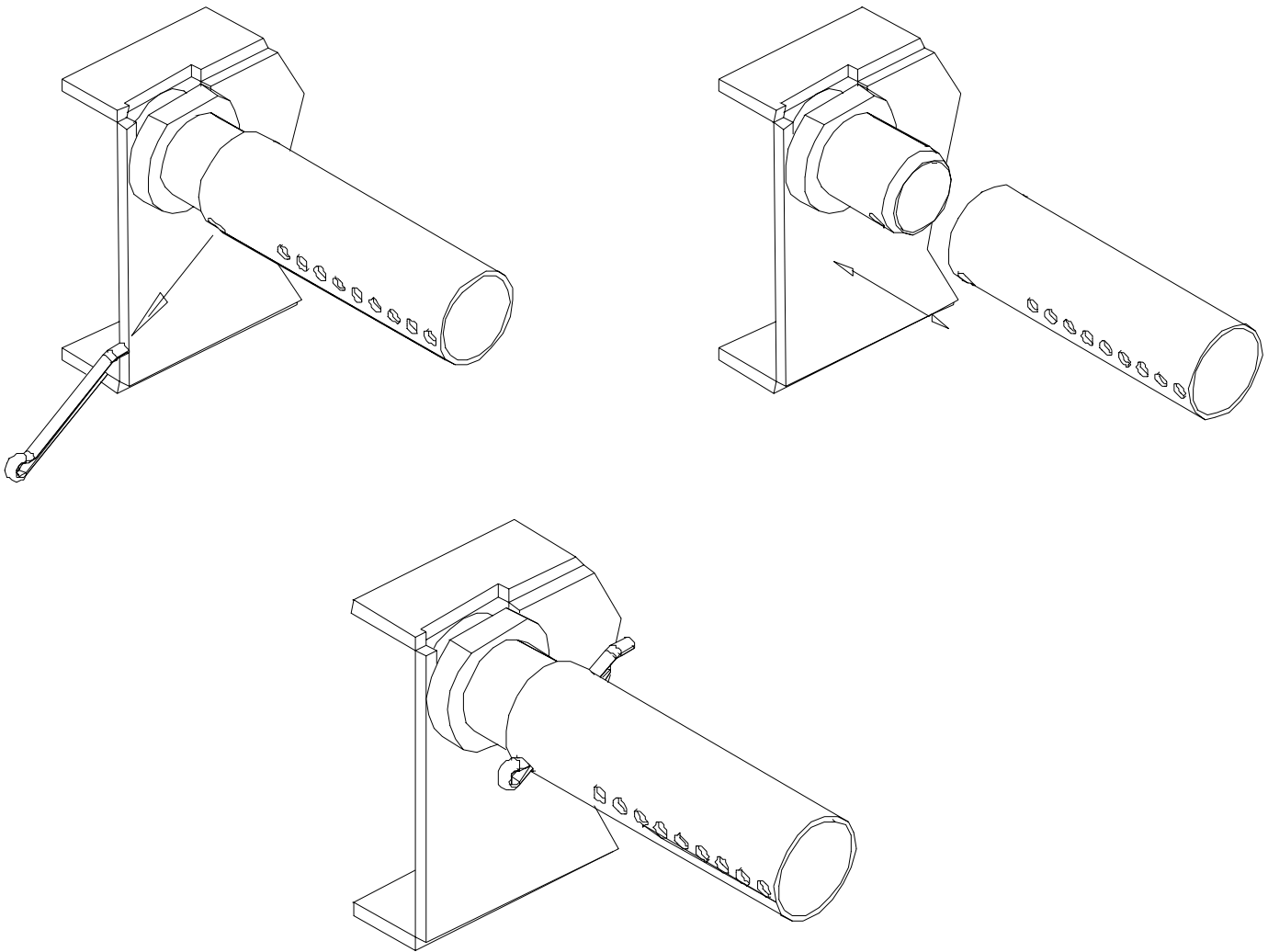

Figure 4.3 – Secondary Air Tube replacement

4.6 Fan Maintenance & Care

Clean the fan air inlet louvres and squirrel cage impeller regularly. The fan should be kept clean and dust free. Life of the fan will be shortened if operated in a dust filled environment, or if the fan is overheated by restricting air supply. Stalling the rotor, or over firing the insert with the fan turned off will also damage the fan. The fan must not be overheated. Do not disassemble the fan. ***"ALTERING***

OR TAMPERING WITH THE FAN WILL VOID THE WARRANTY".

Section 5.0 Troubleshooting

Symptom	Possible Cause	Corrective Action
I Smoke in room	<ol style="list-style-type: none">1. Down draft2. Chimney blocked3. Chimney damper shut4. Baffle out of position5. New paint is curing	<ol style="list-style-type: none">1. Upgrade chimney2. Clean chimney3. Open or remove damper4. Correctly position baffle5. Refer to instructions
II Wood burns poorly or is slow to start or no heat	<ol style="list-style-type: none">1. Low draw2. Wet or decayed wood3. Blocked intake air	<ol style="list-style-type: none">1. Upgrade chimney2. Use proper fuel3. Check intake air supply by removing fan from insert and opening a window
III Dirty glass	<ol style="list-style-type: none">1. Insert is being under fired	<ol style="list-style-type: none">1. Refer to instructions
IV Wood burns too fast	<ol style="list-style-type: none">1. Too much draft in chimney	<ol style="list-style-type: none">1. Install manual damper in chimney connector pipe.

Section 6.0 Specifications

Fuel Type	Cordwood
Test Standards	ULC S628 (CSA B366.2) & UL 1482 residential. AS/NZS 4013:1999 when tested in accordance with AS/NZS 4012:1999
Heat Output Range	11,717 – 30,437 BTU/Hr (at 63% default efficiency). BTU/Hr output will vary with usage depending on the type and condition of cord wood. Maximum average heat output burning hardwood (Australia, New Zealand) 6.8 kW, efficiency on low – 61%, on high – 49%
Shipping Weight	366lbs (166kg)
Firebox Volume	2.2 cu.ft. (0.062 m ³)
Firebox Floor Area	18 3/16 x 17 (478mm x 431mm)
Door Opening Size	21.2" wide x 9.2" high (538 mm wide x 234 mm high)
Recommended Log Size	18" x 6" Dia. (457 mm x 152 mm) if loading sideways 16" x 6" Dia. (406 mm x 152 mm) if loading front to back
Flue Outlet	6" (152 mm) diameter (vertical)
Optional Components	- 29 x 44 Faceplate - 32 x 44 Faceplate - 32 x 50 Faceplate



1700, rue Léon-Harmel, Québec (Québec) G1N 4R9
 tel. : (418) 527-3060 fax : (418) 527-4311
 e-mail : tech@osburn-mfg.com web site : http://www.osburn-mfg.com

LIMITED LIFETIME WARRANTY

The warranty of the manufacturer extends only to the original consumer purchaser and is not transferable. This warranty covers brand new products only, which have not been altered, modified nor repaired since shipment from factory. Proof of purchase (dated bill of sale), model name and serial number must be supplied when making any warranty claim to your OSBURN dealer

This warranty applies to normal residential use only. Damages caused by misuse, abuse, improper installation, lack of maintenance, over firing, negligence or accident during transportation are not covered by this warranty.

This warranty does not cover any scratch, corrosion or discoloration caused by over firing, abrasives or chemical cleaners. Any defect or damage caused by the use of unauthorized parts or others than original parts void this warranty.

An authorized qualified technician must perform the installation in accordance with the Instructions supplied with this product and all local and national building codes. Any service call related to an improper installation is not covered by this warranty.

Returned products are to be shipped prepaid to the manufacturer for investigation. If a product is found to be defective, the manufacturer will repair or replace such defect and reasonable transportation fees will be refund. Repair work covered by the warranty, executed at the purchaser domicile by an authorized qualified technician requires the prior approval of the manufacturer. Labour cost and repair work to the account of the manufacturer are based on predetermined rate schedule and must not exceed the wholesale price of the replacement part.

The manufacturer at its discretion may decide to repair or replace any part or unit after inspection and investigation of the defect. The manufacturer may, at its discretion, fully discharge all obligations with respect to this warranty by refunding the wholesale price of any warranted but defective parts

The manufacturer shall in no event be responsible for any special, indirect, consequential damages of any nature, which are in excess of the original purchase price of the product.

DESCRIPTION	WARRANTY APPLICATION	
	PARTS	LABOUR
Combustion chamber (weldings only)	Lifetime	5 years
Stainless baffle	5 years	1 year
Carbon steel baffle and secondary air tubes	2 years	1 year
Handle assembly	5 years	n/a
Ash drawer	Lifetime	1 year
Cast iron parts	5 years	1 year
Ceramic glass (thermal breakage only)	1 year	n/a
Paint, refractory bricks, gasket, blower, thermal switch (thermodisc) and rheostat	1 year	n/a
Gold plating (tarnishing) / Brass plating not covered	1 year	n/a

Shall your unit or a components be defective, contact immediately your **OSBURN** dealer. Prior to your call make sure you have the following information necessary to your warranty claim treatment:

- You name, address and telephone number;
- Serial number and model name as indicated on the nameplate fixed to the back of your unit;
- Bill of sale, dealer's name;
- Nature of the defect and any relevant information.

Before shipping your unit or defective component to our plant, you must obtain from your OSBURN dealer an Authorization Number. Any merchandise shipped to our plant without authorization will be refused automatically and returned to sender.