



Warnock Hersey
W
C **H**® US

PELLET STOVE

SOLUS

OWNERS TECHNICAL MANUAL

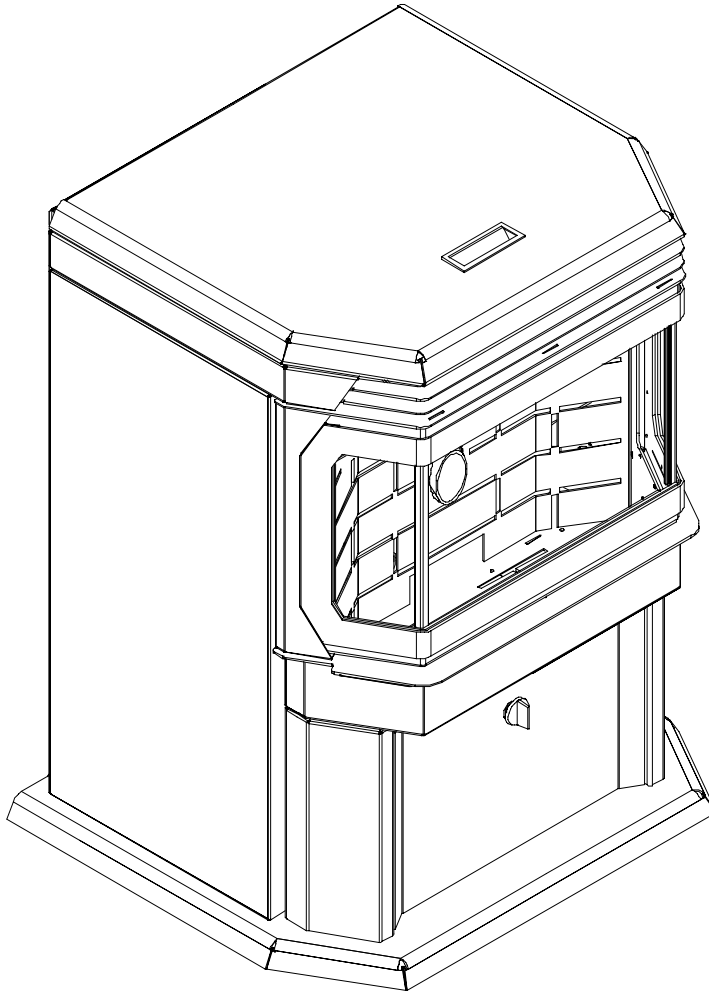

SHERWOOD INDUSTRIES LTD.

6782 OLDFIELD RD

VICTORIA, BRITISH COLUMBIA V8M-2A3

SOLUS INSTALLATION MANUAL

TABLE OF CONTENTS

1) <u>INTRODUCTION</u>	PAGE
Important Safety Data.....	3
Pellet Quality	4
Warnings and Recommendations.....	5
Automatic Safety Features	5
2) <u>OPERATION</u>	
How to Start Your Pellet Appliance.....	6
Turning Your Pellet Appliance Off	6
Slider/Damper.....	7
Clip on Door Installation.....	7
3) <u>SPECIFICATIONS / MAINTENANCE</u>	
Areas for Routine Maintenance	8-10
Electrical Component Functions	10-12
4) <u>INSTALLATION</u>	
Vent Termination Requirements	13
Deciding Where To Locating Your Pellet Appliance	13
Removing Your New Stove From It's Pallet.....	14
Fireplace Dimensions	14
Model FS (Freestanding) Installation.....	15-16
Horizontal Exhaust through the Wall	17-18
Inside Vertical Pipe Installation.....	19
Outside Vertical Pipe Installation	20
Mobile Home Installation	21
Outside Fresh Air Connections.....	21
5) <u>SERVICE</u>	
Troubleshooting.....	22-25
Wiring Diagram.....	26
Warranty.....	27



IMPORTANT SAFETY DATA

To prevent the possibility of a fire, ensure that the appliance is properly installed by adhering to the installation instructions. An ENVIRO dealer will be happy to assist you in obtaining information with regards to your local building codes and installation restrictions.

The stove's exhaust system works with negative combustion chamber pressure and a slightly positive chimney pressure, it is very important to ensure that the exhaust system be sealed and airtight.

This unit is designed to burn pelletized wood fuel only. Do not use any other type of fuel, this will void any warranties stated in this manual.

THE USE OF CORDWOOD IS PROHIBITED BY LAW.

Do not burn with insufficient combustion air. A periodic check is recommended to ensure proper combustion air is admitted to the combustion chamber. Setting the proper combustion air is achieved by adjusting the slide damper located on the left side of the stove.

It is advisable to clean the exhaust vent bi-annually or every two tons of pellets.

The grounded electrical cord should be connected to a standard 115 volts, 60-hertz electrical outlet. Be careful that the electrical cord is not trapped under the appliance and that it is clear of any hot surfaces or sharp edges. This unit's maximum power requirement is 520 watts (4.52 Amps) for the **SOLUS**.

Minor soot or creosote may accumulate when the stove is operated under incorrect conditions such as an extremely rich burn (black tipped, lazy orange flames).

When installing the stove in a mobile home, it must be electrically grounded to the steel chassis of the home and bolted to the floor. Make sure that the structural integrity of the home is maintained.

Be sure to maintain the structural integrity of home when passing a vent through walls, ceilings, or roofs.

The ash pan must be locked securely for proper and safe operation of the pellet stove.

If you have any questions with regards to your stove or the above-mentioned information, please feel free to contact your local dealer for further clarification and comments.

Since Sherwood Industries Ltd. has no control over the installation of your stove, we grant no warranty implied or stated for the installation or maintenance of your stove, therefore, Sherwood Industries Ltd. assumes no responsibility for any consequential damage.

SAVE THIS INSTRUCTION MANUAL FOR FUTURE REFERENCE

PELLET QUALITY IS IMPORTANT, PLEASE READ THE FOLLOWING PAGE

Your pellet stove has been designed to burn wood pellets only. Since there are many manufacturers of wood pellets it is important to select pellets that are free of dirt or any impurities. The Pellet Fuel Industries (P.F.I.) has established standards for wood pellet manufactures. We recommend the use of pellets that meet or exceed these standards. Ask your dealer for a recommended pellet type.

THE PERFORMANCE OF YOUR PELLET STOVE IS GREATLY EFFECTED BY THE TYPE AND QUALITY OF WOOD PELLETS BEING BURNED. AS THE HEAT OUTPUT OF VARIOUS QUALITY WOOD PELLETS DIFFER, SO WILL THE PERFORMANCE AND HEAT OUTPUT OF THE PELLET STOVE.

Since Sherwood Industries Ltd. has no control over the quality of pellets that you use, we assume no liability caused by the quality of wood pellets used.

P.F.I. PELLET STANDARDS:

Fines	1% maximum through a 1/8" screen
Bulk Density	40 lbs. per cubic foot minimum
Size	1/4" to 3/8" diameter 1 – 1.5" long maximum
Ash Content	1% maximum
Moisture Content.....	8% maximum
Heat Content.....	approximately 8200 Btu per lb. minimum

Check the burn-pot liner periodically to ensure that the holes are not blocked with clinkers, (clinkers are silica in the fuel that will form a hard mass during the burning process). If they are blocked, remove the liner (when the unit is cold) and clean the clinkers out. The liner should be cleaned or scraped once every 2-3 days depending on wood pellet quality. Clean the holes in the lines with a small pointed object.

Store pellets at least 36" (1 m) away from the pellet stove.

WARNINGS AND RECOMMENDATIONS

- A. Do not abuse the glass by striking or slamming the door shut.
- B. Do not attempt to operate the stove with broken glass.
- C. Do not attempt to open the door and clean the glass while the unit is in operation. To clean the glass, use a soft cotton cloth and mild window cleaner, gas or wood stove glass cleaner or take a damp paper towel and dip into the fly ash, this is a very mild abrasive and will not damage the glass.
- D. Do not use abrasive cleaners to clean the surface or any part of the stove.
- E. It is recommended that the unit be secured into its position in order to avoid any displacement.
- F. Never use gasoline, gasoline-type lantern fuel, kerosene, or similar liquids to start the fire. Keep all such liquids well away from the pellet stove while it is in use.
- G. Disposed ashes should be placed in a metal container with a tight fitting lid. The closed container of ashes should be on a non-combustible floor on the ground, well away from all combustible materials pending final disposal. The ashes should be retained in the closed container until all cinders have thoroughly cooled before disposing of them.
- H. Make sure the ash pan is closed tightly during the operation of the stove.
- I. **KEEP ASH PAN FREE OF RAW FUEL. DO NOT PLACE UNBURNED OR NEW PELLET FUEL IN ASH PAN.** A fire in the ash pan could be the result.
- J. Fresh air intake is strongly recommended. Failure to install Intake air may result in the unit smoking during power failures as well as improper combustion.

NOTE: Fresh air is mandatory on all units installed in “Mobile Homes” as well as “Air Tight” homes.

AUTOMATIC SAFETY FEATURES OF YOUR PELLET STOVE

- A. The stove will shut off when the fire goes out and the exhaust temperature drops below 120°F (49°C).
- B. The stove has a high temperature safety switch. If the temperature on the hopper reaches 200°F (93°C) the auger will automatically stop, and the stove will shut down when the exhaust temperature cools. If this happens call your local dealer to reset the 200°F (93°C) high limit switch. **ALSO FIND THE REASONS WHY THE UNIT OVERHEATED.**
- C. The unit has a convection fan control over-ride. This function causes the convection fan to reach its full speed when the temperature at the back of the firebox reaches 160°F (71°C). This is a normal safety feature of your unit. To compensate for the fan cycling action that may occur, turn up the blower control proportionately to the heat output.
- D. If the power goes out, the unit will stop running. When the power comes back on, the stove will not restart unless the exhaust temperature is still above 120°F (49 °C).

HOW TO START AND OPERATE YOUR PELLET APPLIANCE

1. Check and fill hopper with pellets.
2. Make sure unit is plugged into a working outlet.
3. Switch the power “ON” by pushing the start up switch once only.
4. Turn knob “B” to the 12 o’clock position. (**Lower grade pellets may need a higher setting on the feed rate**). **NOTE:** unit will take longer to light if the hopper has been completely emptied.
5. Wait until the fire is established, then turn knob “B” to the desired heat output. (The stove may not be able to burn in the BLUE ZONE if poor quality wood pellets are being used. Adjust the Slider Damper to the appropriate setting (SEE PAGE 8).

Convection
Blower Speed
Control
KNOB A

Auger Light

Start-up
Switch

Dial-A-Fire
Heat Output
Knob
Knob B

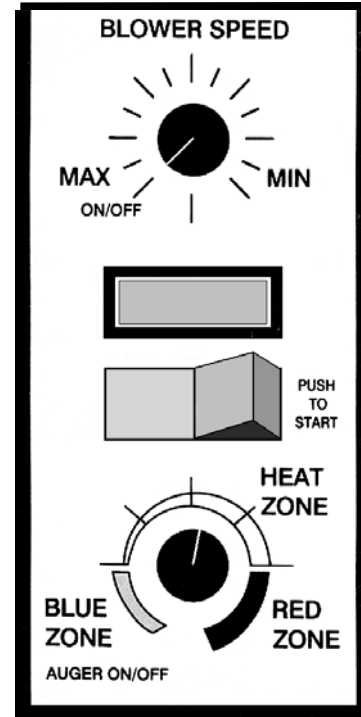

6. If the stove should shut off after 15 minutes and there is still a fire in the firebox – press the start up switch once more. If the fire went out, return to step number 2 and re-light the stove.

KNOB “A”: Fan Controller. By adjusting the knob you will vary the rate of airflow into the room by varying the speed of the convection blower. When you first start the stove it should be placed in the “OFF” position in order to heat the unit as quickly as possible. Once the room has come up to temperature the control may be set to a comfortable level. ***Note:** The convection blower may cycle to high automatically depending on the setting of knobs “A” and “B”. This is a normal safety feature of the unit.

The flashing green **“Auger Light”** corresponds to the timing of the auger turning.

KNOB “B”: Dial a Fire Heat Output Knob. This knob controls the amount of heat output. The dial has a scale with the **blue zone** representing the coolest setting of the stove, and the **red zone** representing the hottest setting. The scale on knob “B” represents a range, not exact at times or fuel quantities. Wood pellets of differing quality may effect the performance of the stove. If the stove has trouble operating at either end of its range, turn the heat output knob back slightly.

TURNING YOUR PELLET STOVE OFF

To turn your stove off, simply turn the HEAT OUTPUT knob (knob “B”) counter-clockwise until the knob clicks to the “OFF” position. This will stop the feed of pellets. The blowers will continue to run and cool the stove. When cool enough, the stove will shut down.

SLIDER/DAMPER INSTALLATION INSTRUCTIONS

This is used to regulate the airflow through the pellet stove.

A Qualified Service Technician or Installer should set the Slider Damper.

The Slider Damper is pre set from the factory. The slider damper will be set and held in place with a 5/16" hex head screw. This screw will be tightened in the middle of the slot located in the slider damper plate.

The slider damper is located behind the left side panel. To open the left side panel, undo the one screw located in the upper front corner of the cabinet side

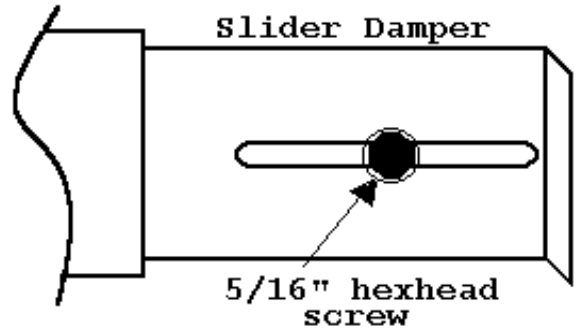

The combustion exhaust blower is a variable speed blower controlled by the heat output knob,(Dial a Fire). This blower will decrease the vacuum pressure inside the stove and as the heat output knob is turned up. The vacuum pressure inside the firebox will increase as the combustion exhaust blower increases in speed.

SPECIAL NOTES:

Pellet quality is a major factor in how the Pellet stove will operate. If the Pellets have a high moisture content or ash content the fire will be less efficient and has a higher possibility of the fire building up and creating clinkers. (hard ash build-up)

If the fire should happen to go out and the Dial A Fire has been set on the lowest setting, the Slider Damper should be pushed in slightly decreasing the air in the firebox.

If after long periods of burning the fire builds up and over flows the burn pot or there is a build up of clinkers This would be a sign that the pellet quality is poor and the slider damper must be pulled out to compensate.

Pulling the slider damper out gives the fire more air.

The easiest way to make sure that an efficient flame is achieved is to see the characteristics of the fire.

- A tall and lazy flame with dark orange tips requires more air – Open slider / damper up.
- A short and brisk flame, like a blowtorch, has too much air – Close slider / damper down.
- If the flame is in the middle of these two characteristics with a bright yellow/orange, active flame then the air is set for proper operation.

CLIP ON DOOR INSTALLATION

1. Unlatch door and swing open, remove door form unit.
2. Place door on a soft flat surface and remove the (4) screws (2 on each side) that hold the side trim pieces to the door.
3. Undo all four screws that hold the outer clip on the door.
4. Install the new (GOLD or NICKEL) clip on door using the four screws to fasten to the door.
5. Reinstall the side trim pieces using the screws that were removed from step 1.
6. Reinstall the door on the unit and latch with the handle provided.

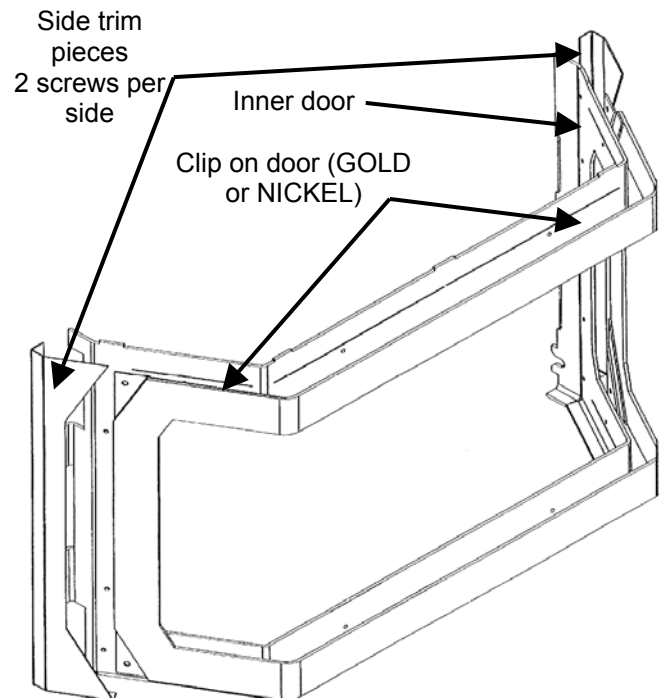

AREAS FOR ROUTINE INSPECTION

The following should be inspected periodically to ensure that the appliance is operating at its optimum and giving you excellent heat value:

2 3 DAYS/WEEKLY

Burn Pot and Liner
Ash Pan
Inside Firebox
Behind Firebox Liners
Burn Pot and Liner
Door Glass
Heat exchanger tubes
Ash pan and Door gaskets

SEASON or 2 TONS OF FUEL

Exhaust Vent
Fresh air Intake Tube
Blower Mechanisms
Heat exchanger tubes
Latch Mechanism of ash pan
Door Latch
All Hinges
Post Season Clean-up

TOOLS REQUIRED TO CLEAN UNIT:..Torx T-20 Screwdriver, Brush, Soft Cloth, Vacuum with fine filter bag

ASH PAN AND DOOR GASKETS

After excessive use the gasketing may come loose. To repair this, glue the gasketing on using high-temperature fiberglass gasket glue available from your local dealer. This is important to maintain an airtight assembly. **DO NOT PLACE UNBURNED OR RAW PELLET FUEL IN ASH PAN.**

BURNER POT AND LINER

This is the 'pot' where the pellets are burned. Every two to three days (when the unit is cold), remove the burn-pot liner from the stove. Using a metal scrapper remove material that has accumulated or is clogging the liner's holes. Then dispose of the scrapped ashes from the liner and from inside the burn-pot. Place the burn-pot back into the stove, making sure that the pipes are properly inserted into the burn pot and the front tabs are in place in the firebox. Place the liner back into the burn-pot, making sure that the ignitor hole in the liner is aligned with the ignitor tube. Pushing the liner up against the ignitor tube.

To remove the burn pot and burn pot liner open the door using the door handle provided located on the left-hand side of the stove, swing the door open. Lift the liner from the burn pot, lift the burn pot from the firebox by gently lifting the front of the burn pot up first then sliding the assembly from the air intake tube and the igniter cartridge.

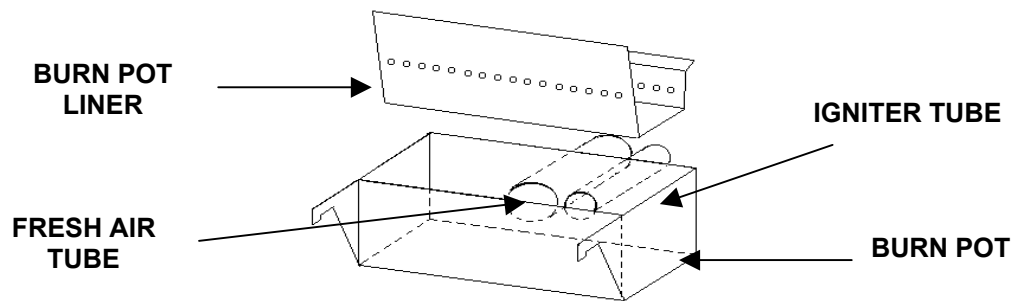

ASH PAN: (# 1 SEE PAGE 10)

This part is located under the burner, in the pedestal and has a latching mechanism to secure it. To remove the ash pan, unlock the latch on the pedestal cover and then pull the pan out. Dump the ashes into a metal container stored away from combustibles. Monitor the ash level every week. **Remember that different pellet fuels will have different ash contents.** Ash content is a good indication of fuel efficiency and quality. Refer to "Warnings and Recommendations" for disposal of ashes.

BLOWER MECHANISMS (# 2 SEE PAGE 10)

Unplug the stove then open the right/left side panels to access the two blowers. Only the convection blower motor (on the right side of the stove) will require lubrication. The convection motor has two lubrication holes on it. Use two drops of SAE 20, light oil to lubricate every six months. Excess oil may damage the motor. The exhaust blower's motor has sealed bearings, DO NOT lubricate this motor.

DOOR GLASS

(It is recommended that your dealer replace the glass if broken.)

The door glass is made of high temperature PYROCERAMIC The center panel is 246mm x 383mm and the two outside pieces are 246mm x 107mm. To replace the glass, unscrew and remove the four glass retainers. Remove the glass and any broken pieces. High temperature fiberglass tape should be used around the glass. Replace the glass, then screw the glass retainers back to the frame.

FRESH AIR INTAKE

Inspect periodically to be sure that it is not clogged with any foreign materials.

EXHAUST PASSAGES (# 3 SEE PAGE 10)

For BI-weekly clean out, ash may be removed from behind the steel plates by rotating the circular covers located behind the right and left side panels. To open the side panels undo one T20 Torx screw on each side(TOP, FRONT). When the side cabinet doors have been opened there are two round disks at the bottom of the firebox, loosen the screw on the disks and open, this will allow vacuuming behind the firebox liners plates.

Removal of the fire box backing for BI-annual cleaning (# 4 SEE PAGE 10)

- Open the door with the handle provided, Remove the burn pot and burn pot liner.
- Lubricate all screws with penetrating oil.
- Undo the four screws and remove the firebrick liner.
- Remove the two top baffles.
- Just above the ash sill there are two screws that hold the firebox liners in place, remove these two screws.
- With the tip of a flat screwdriver, gently lift up the side panels and remove the side panels.
- Pull the center panel out.
- Vacuum thoroughly.

Installation of fire box backing:

- Insert center panel.
- Place the side panels back into the firebox and reinstall the two lower screws, Install top baffles.
- Replace the firebrick liner.
- Replace the glass door and secure.
- Clean thoroughly.

EXHAUST VENT

This vent should be cleaned every year or after two tons of pellets. We recommend contacting your dealer for professional cleaning. To clean the vent pipe, tap lightly on the pipe to dislodge any loose ash. Open the bottom of the "T" to dump the ash, then vacuum as much of the ash out of the vent pipe as possible.

HEAT EXCHANGER TUBES (# 5 SEE PAGE 10)

A handle is located under the hopper lid, in the center of the stove just above the door. This handle is to be pulled up and down a few times (**ONLY WHEN THE UNIT IS COLD**) in order to clean away any fly ash that may have collected on the heat exchanger tubes. As different types of pellets produce different amounts of ash, cleaning of the tubes should be done on a regular basis to enable the unit to run efficiently.

POST SEASON CLEAN-UP

Once you are finished using the pellet appliance for the season, unplug the stove for added electrical protection. It is very important that the stove be cleaned and serviced as stated above. (See Section Areas of Routine Inspection)

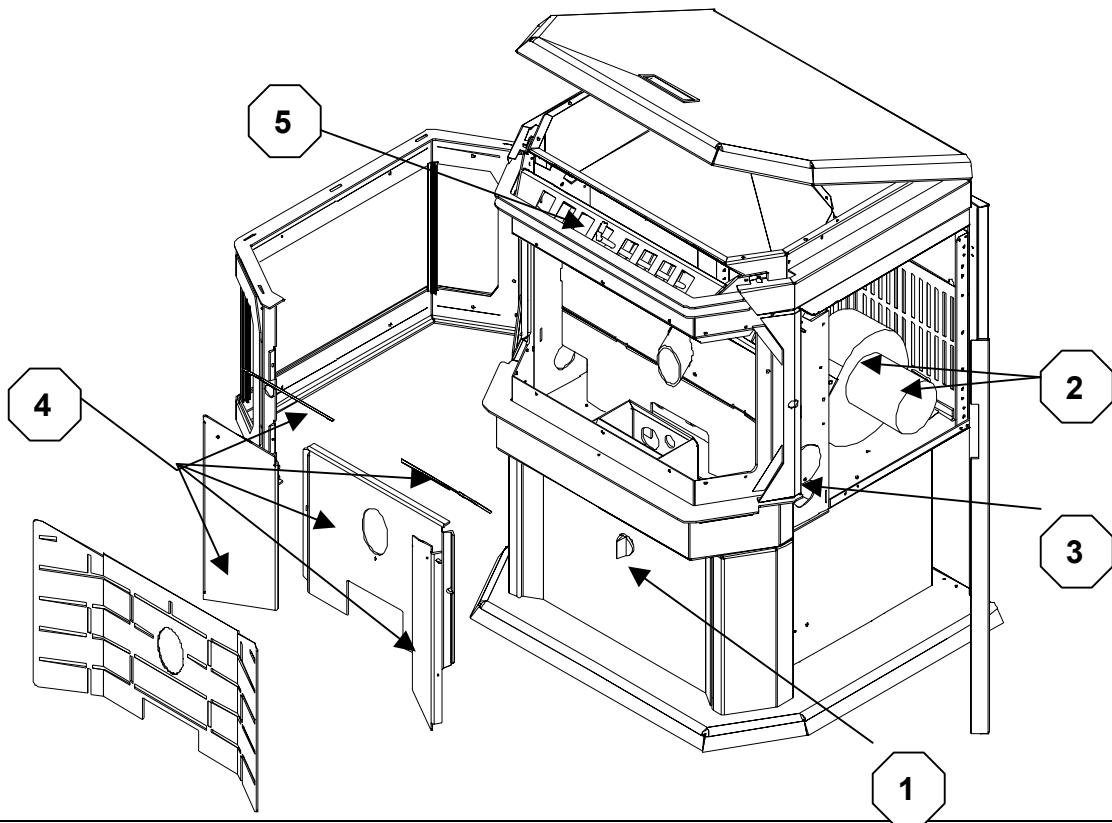

ELECTRICAL COMPONENT FUNCTIONS

The following is a list of electrical components and their functions on the *ENVIRO SOLUS* pellet stove.

1. CONVECTION FAN CONTROLLER

This controller is responsible for varying the speed of the convection blower. Should the convection blower be set on low and dial-a-fire set on high, the 160°F (71°C) Temp. Sensor will by-pass the fan controller and the fan will go to full speed. This will cool the stove until control is given back to the fan controller

2. AUGER PULSE LIGHT

This light will flash in conjunction with the pulses to the auger.

3. START-UP SWITCH

When this momentary contact switch is pressed it will initiate the 15-minute start-up cycle including the ignitor.

4. DIAL-A-FIRE (HEAT OUTPUT CONTROL)

This unit is responsible for controlling the timing of the auger motor. When turned clockwise it will cause the OFF time between auger pulses to shorten, resulting in more heat output and pellet consumption. Turn the knob counter-clockwise and the reverse will happen. When it is turned fully counter-clockwise past the click, the auger motor will be off. This component also controls the exhaust blower speed Via the Speed Control Module

5. CONVECTION BLOWER

This blower fan,(mounted on the right side of the stove) draws room air from the back of the stove and passes the air through the heat exchanger tubes and back into the room. The sealed system keeps the room air separate from the combustion air. The convection blower's fan controller controls this fan's speed.

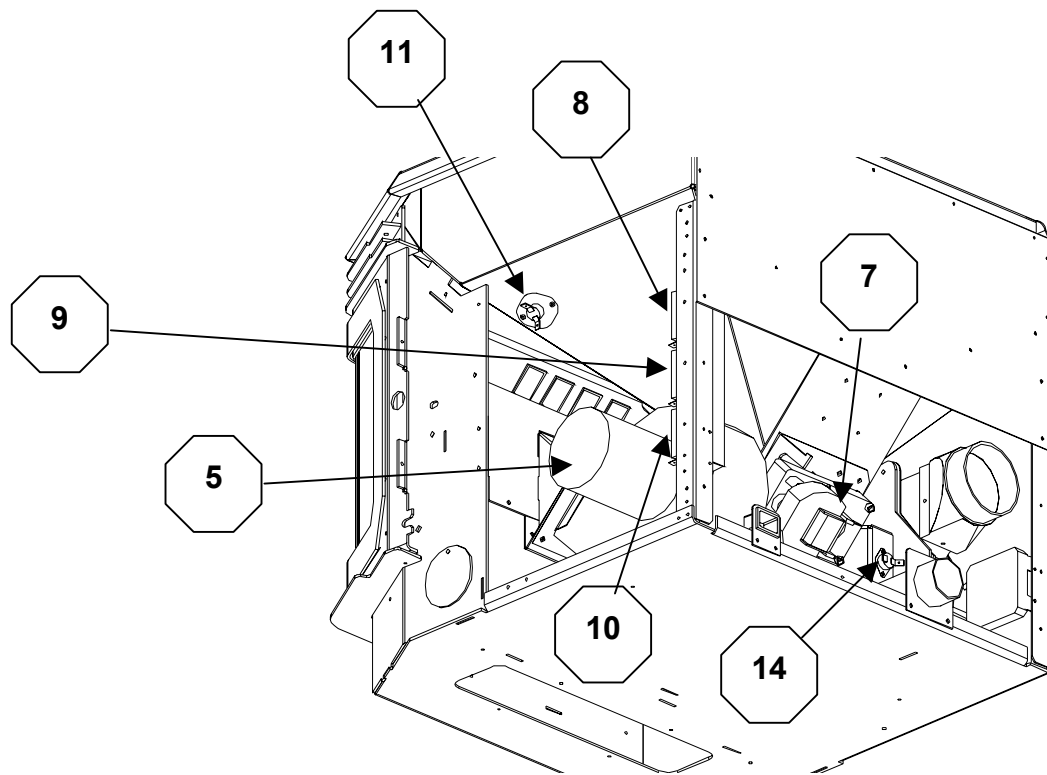

6. EXHAUST/COMBUSTION BLOWER

This variable speed fan (mounted on the left side of the stove) is responsible for drawing the outside fresh air into the combustion chamber for burning. The hot air then continues to be drawn over the heat exchanger tubes and into the exhaust channel. It is then pushed out through the exhaust system. A motor speed controller tied in with the Dial-A-Fire controls the speed of the blower.

7. AUGER MOTOR AND AUGER

The 1 rpm auger motor is responsible for turning the auger, which in turn transports pellets to be dropped into the burn pot. The auger motor's control is handled by the timing control module and Dial-A-Fire.

8. EXHAUST/COMBUSTION PHASE CONTROLLER (BLOWER SPEED CONTROL MODULE)

The phase controller supplies an adjustable voltage to the combustion blower. The voltage controls the blower's speed. The module is controlled by a potentiometer in the Dial a Fire. As the feed rate is increased, the blower's speed is increased proportionally.

9. TIMING CONTROL MODULE

The timing control module is mounted in the middle, on the right rear pillar of the stove. The module controls the switching of power to the auger motor. The module's switching duty cycle is controlled by the dial-a-fire.

10. START-UP TIMER

This 15-minute one-shot timer, bypasses the 120°F (49°C) temperature sensor allowing the stove to operate when cold. The timing cycle is initiated by pressing the start-up switch. The 15-minute timer is located right under the timing control module on the right side pillar. This unit is also responsible for initiating the ignition cycle.

11. 200°F (93°C) MANUAL RESET TEMPERATURE SENSOR

This sensor (located on the right side firewall) has a red push button located in its center. This is a safety device. In the event that the convection blower fails, this sensor will overheat and shut off power to the auger motor.

12. 160°F (71°C) TEMPERATURE SENSOR

When this sensor (located on the left side firewall) reaches 160°F (71°C), the convection blower will go to high, bypassing the fan controller and removing excess heat from the unit.

13. 120°F (49°C) N/O TEMPERATURE SENSOR (SHUT-DOWN SENSOR)

This sensor (mounted on the exhaust blower housing) has two functions:

- Should the fire go out, this sensor will shut the stove off when the exhaust temperature drops below 120°F (49°C).
- When the auger is turned off via the dial-a-fire, the exhaust temperature will drop, when it goes below 120°F (49°C) the sensor will turn the stove off.

14. 120°F (49°C) N/C TEMPERATURE SENSOR (IGNITOR SHUT DOWN SENSOR)

This sensor (mounted on the exhaust channel) will turn the ignitor off when the firebox temperature reaches 120°F (49°C).

15. VACUUM SWITCH

This safety device (mounted on the left side back pillar) detects vacuum in the exhaust system. If the exhaust blower fails or the vent pipe becomes plugged, this switch will sense that there is no airflow and will stop the auger from continuing to feed pellets.

16. IGNITER

This is a heating element used to ignite the fuel. When the pellet stove is started, the igniter is energized. Air passes through the igniter tube over the igniter. The air becomes super heated, drying the fuel and then igniting the pellets through convection. The igniter is located in the lower center of the firebox next to the inlet air tube.

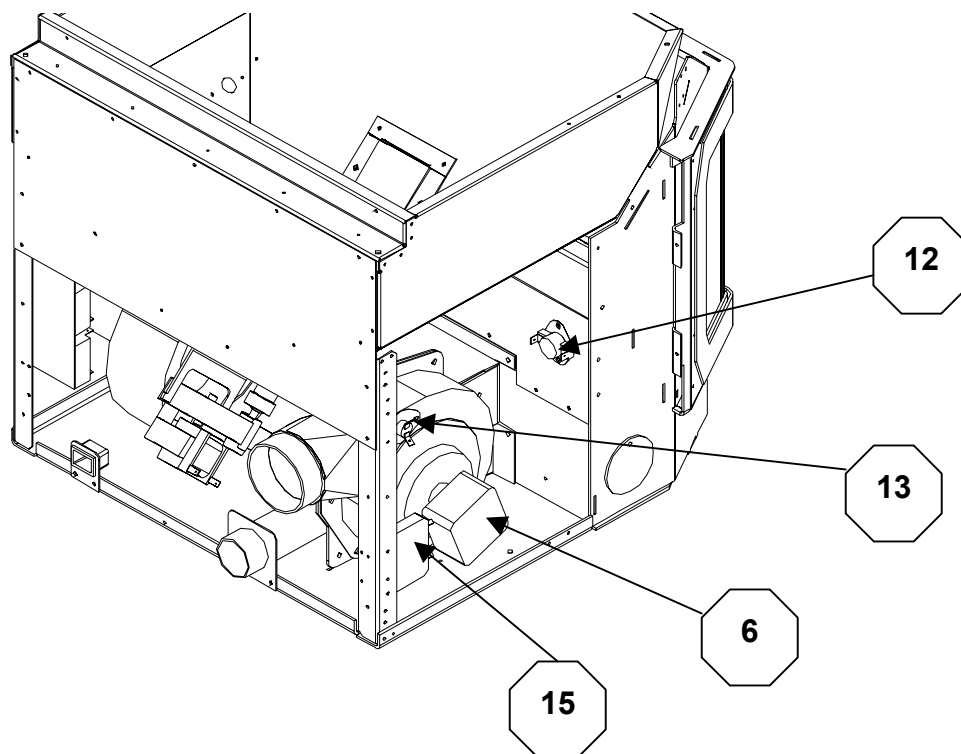

DECIDING WHERE TO LOCATE YOUR PELLET APPLIANCE

1. Check clearances to combustibles.
2. Do not obtain combustion air from an attic, garage or any unventilated space. Combustion air may be obtained from a ventilated crawlspace.
3. Do not install the stove in a bedroom.
4. You can vent the stove through an exterior wall behind the unit or connect it to an existing masonry or metal chimney (must be lined if the chimney is over 6" in diameter, or over 28 sq. inches cross sectional area). An interior vent can be used with approved pipe passing through the ceiling and roof.
5. Locate the stove in a large and open room that is centrally located in the house. This will optimize heat circulation.
6. The power cord is 8 feet (2.43 m) long and may require a grounded extension cord to reach the nearest electrical outlet.

VENT TERMINATION REQUIREMENTS

- A. Do not terminate the vent in any enclosed or semi-enclosed areas such as a carport, garage, attic, crawlspace, narrow walkway, closely fenced area, under a sundeck or porch, or any location that can build up a concentration of fumes such as stairwells, covered breezeway, etc.
- B. Vent surfaces can become hot enough to cause burns if touched by children. Non-combustible shielding or guards may be required.
- C. Termination must exhaust above the inlet elevation. It is recommended that at least five feet of vertical pipe be installed outside when the appliance is vented directly through a wall to create some natural draft to prevent the possibility of smoke or odor during appliance shut down or power failure. To keep exhaust from causing a nuisance or hazard from exposing people or shrubs to high temperatures. In any case, the safest and preferred venting method is to extend the vent through the roof vertically.
- D. Vent terminal cannot be:
 - less than 4 feet (1.2 m) below
 - less than 4 feet (1.2 m) horizontally from, and
 - less than 1 foot (305 mm) aboveDoors, window openings, or gravity/ventilation air inlet into building:
- E. Distance from bottom termination and grade –12" (305 mm) minimum. This is conditional upon the plants and nature of grade surface. The exhaust gases are hot enough to ignite grass, plants and shrubs located in the vicinity of termination. The grade surface must not be lawn. Distance from bottom of termination and public walkways is 7 feet (2.1 m) minimum.
- F. Distance to combustible materials is 2 feet (610 mm). This includes adjacent buildings, fences, protruding parts of the structure, roof overhang, plants, shrubs, etc.
- G. When installing an **FPI** the chimney must be fully lined. Unless the chimney's inside diameter is less than 6" around or has a cross section area of 28 square inches, we strongly recommend lining all masonry chimneys.
- H. If the unit is incorrectly vented or the air to fuel mixture is out of balance, a slight discoloration of the exterior of the house might occur. Since these factors are beyond Sherwood Industries LTD's. control, we grant no guarantee against such incidents.

IT IS RECOMMENDED THAT AN AUTHORIZED DEALER/INSTALLER INSTALL YOUR PELLET STOVE

REMOVING YOUR NEW STOVE FROM THE PALLET

To remove your new stove from its pallet, Turn ash pan latch to open and remove Ash Pan from unit. Remove two securing screws from inside of the pedestal.

REMOVE
HOLDING
SCREWS TO
REMOVE
FROM PALLET

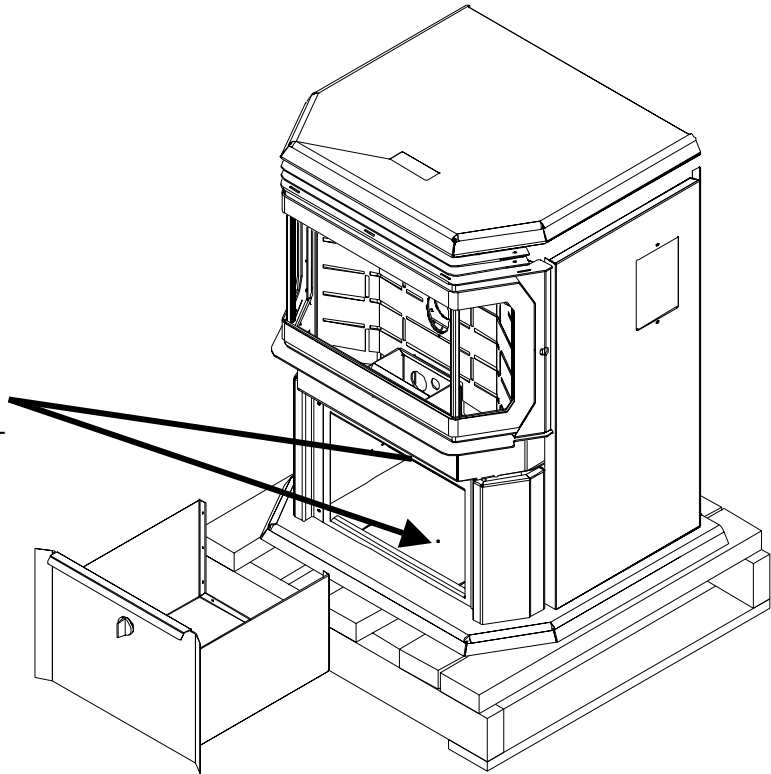

FIREPLACE DIMENSIONS

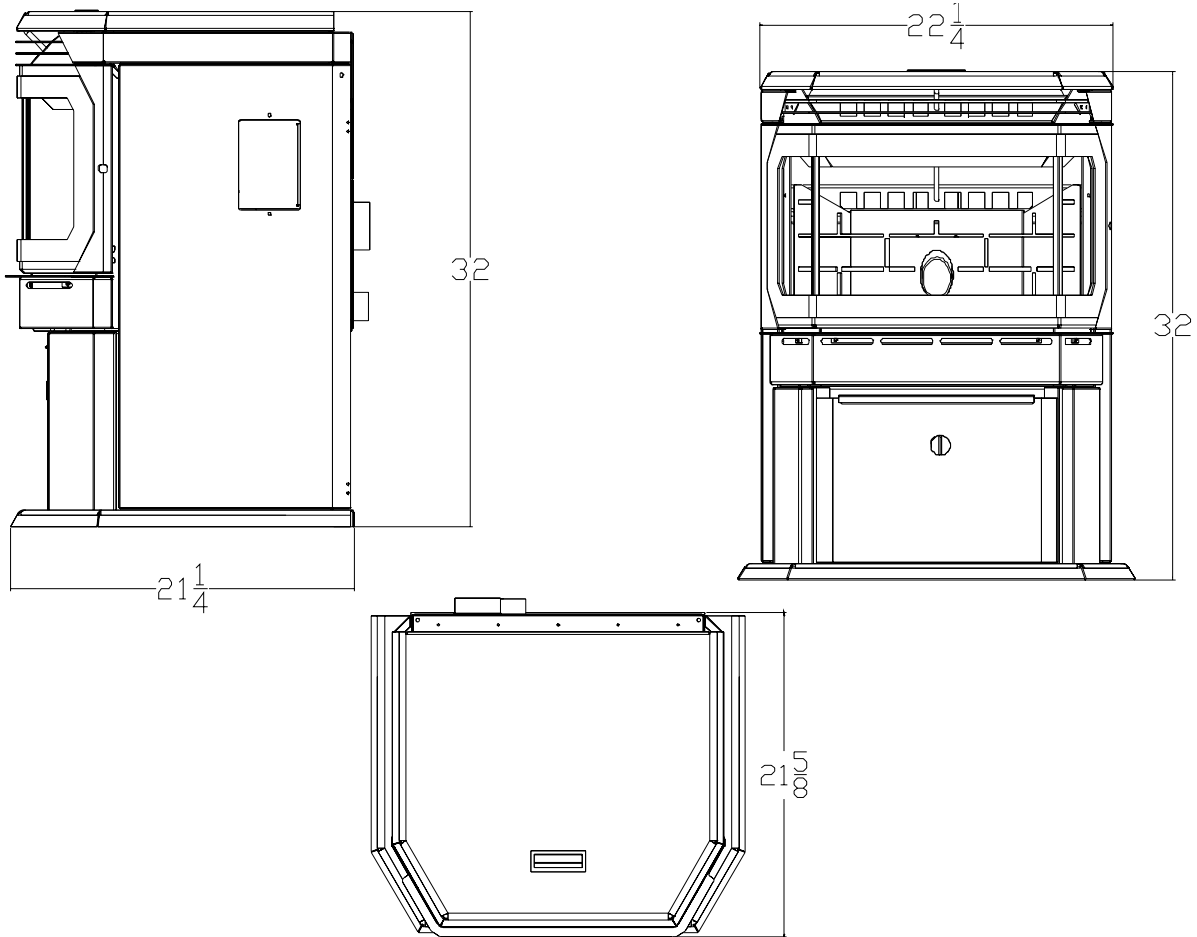

FREESTANDING INSTALLATION, MODEL FS

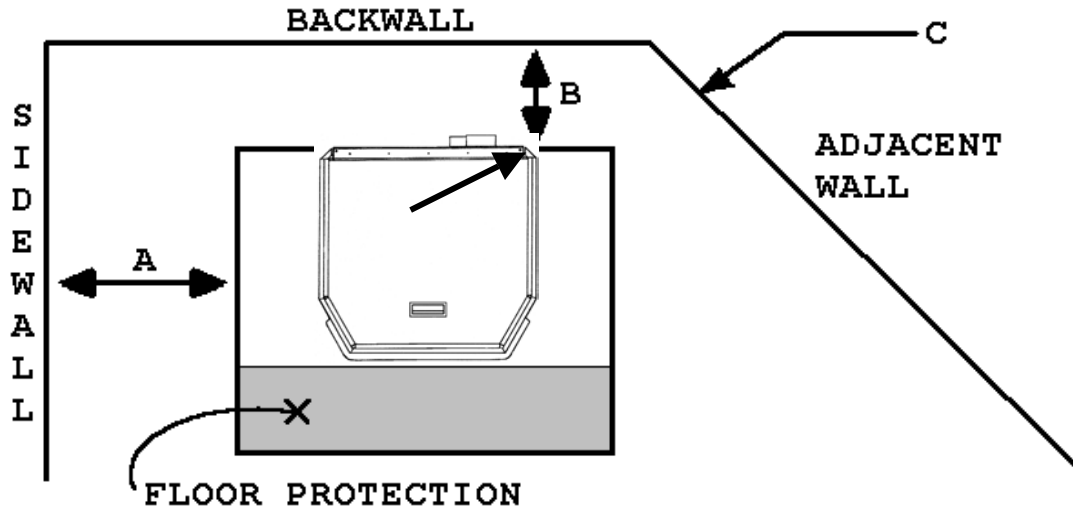

CLEARANCE TO COMBUSTIBLES

This unit must be installed on a noncombustible hearth pad, extending at least 6" (inches) (150 mm) in front of the appliance and at least the entire width of the appliance.

- Side wall to unit A- 6 INCHES (150 mm)
- Back wall to unit B- 2 INCH (50 mm)
- Corner to unit C- 2 INCH (50 mm)
- Front of hearth pad to unit....D- 6 INCHES (150 mm)(Floor Protection)

ALCOVE CLEARANCES

- Alcove width36 inches (900 mm)
- Alcove height.....48 inches (1200 mm)
- Alcove depth.....48 inches (1200 mm)

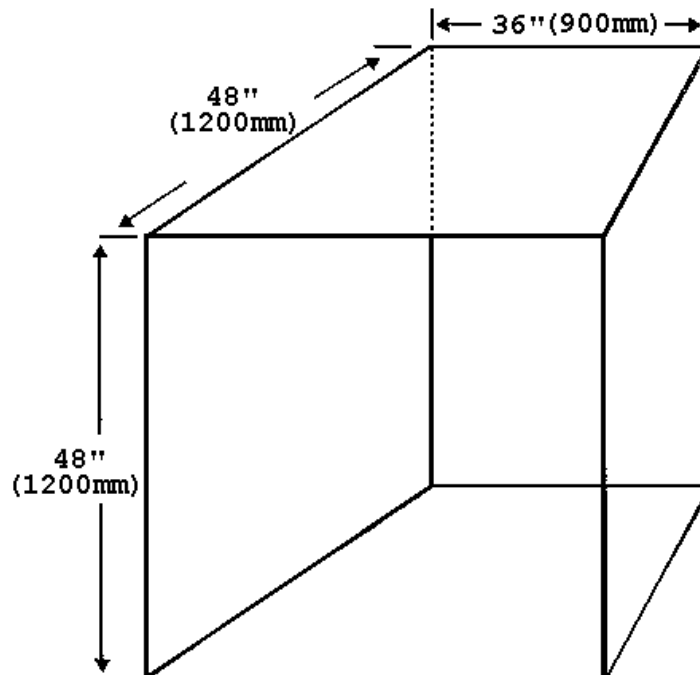

- Side wall to unit E 6 INCHES (152 mm)
- Mantle to unit F 10 INCHES (254 mm)
- Top facing to unit G 8 INCHES (203 mm)
- Floor protection D 6 INCHES (152 mm)

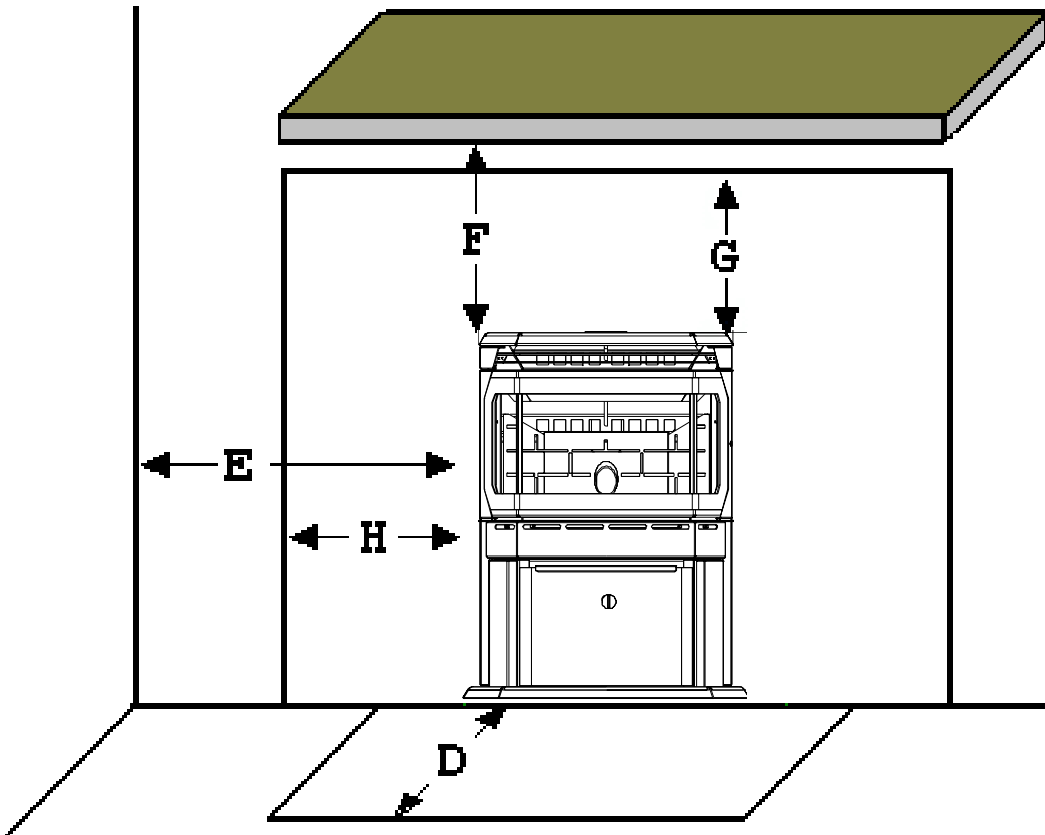

HORIZONTAL EXHAUST THROUGH THE WALL

1. Choose a location for your stove that meets the requirements stated in this manual and allows installation with the least amount of interference to house framing, plumbing, wiring, etc.
2. Install a non-combustible hearth pad (where necessary).
3. Place the appliance 15" (37.5 cm) away from the wall. If the stove is to be set on a hearth pad, set the unit on it.
4. Locate the center of the exhaust pipe on the stove. Extend that line to the wall. Once you have located the center point on the wall, use a hole saw to cut a 7" (175 mm) diameter hole for a 3" (76 mm) vent pipe or an 8" (200 mm) hole for a 4" (101 mm) vent pipe.
5. Install the wall thimble as per the instructions written on the thimble.
6. Install a length of 3" (76 mm) or 4" (101 mm) vent pipe into the wall thimble. The pipe should install easily into the thimble.
7. Install the fresh air intake (SEE PAGE 23)
8. Connect the exhaust vent pipe to the exhaust pipe on the stove. Seal the connection with high temperature silicone
9. Push the stove straight back, leaving a minimum of 2" (5 cm) clearance from the back of the stove to the wall. Seal the vent pipe to the thimble with high temperature silicone.
10. The pipe must extend at least 12' (30 cm) away from the building. If necessary, bring another length of pipe (PL type) to the outside of the home to connect to the first section. Do not forget to place high temperature silicone around the pipe that passes through the thimble.
11. Install a vertical pipe, or if all requirements for direct venting are met, install vent termination. The stainless steel cap termination manufactured by the vent manufacturer is recommended. However, when the vent terminates several feet above ground level and there are no trees, plants, etc. within several feet, a 45-degree elbow can be used as termination. The elbow must be turned down to prevent rain from entering.

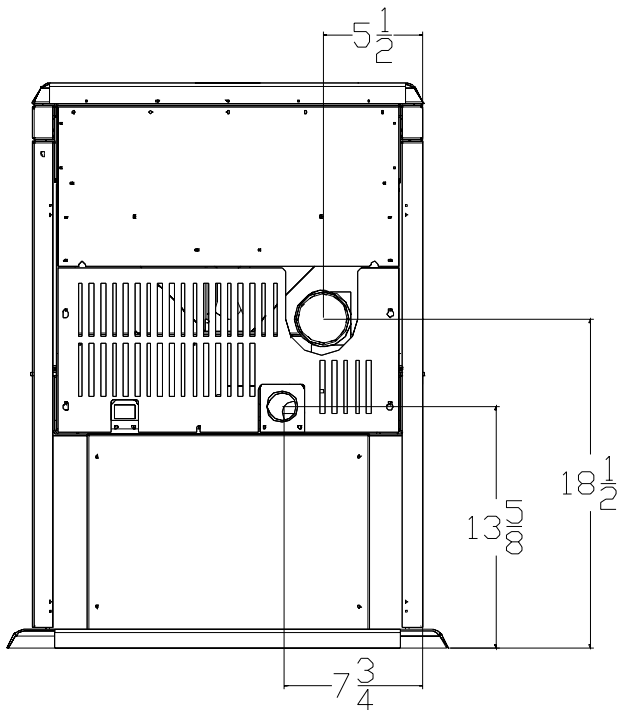

Note: Some horizontal, through the wall installations may require a "T" and 4-5 feet (122 to 152 cm) of vertical pipe outside the building to help the stove draft properly. This may be required if a proper burn cannot be maintained, after the stove has been tested and the airflow set. This is due to backpressure in the exhaust, caused by the airflow around the house.

THROUGH WALL INSTALLATION

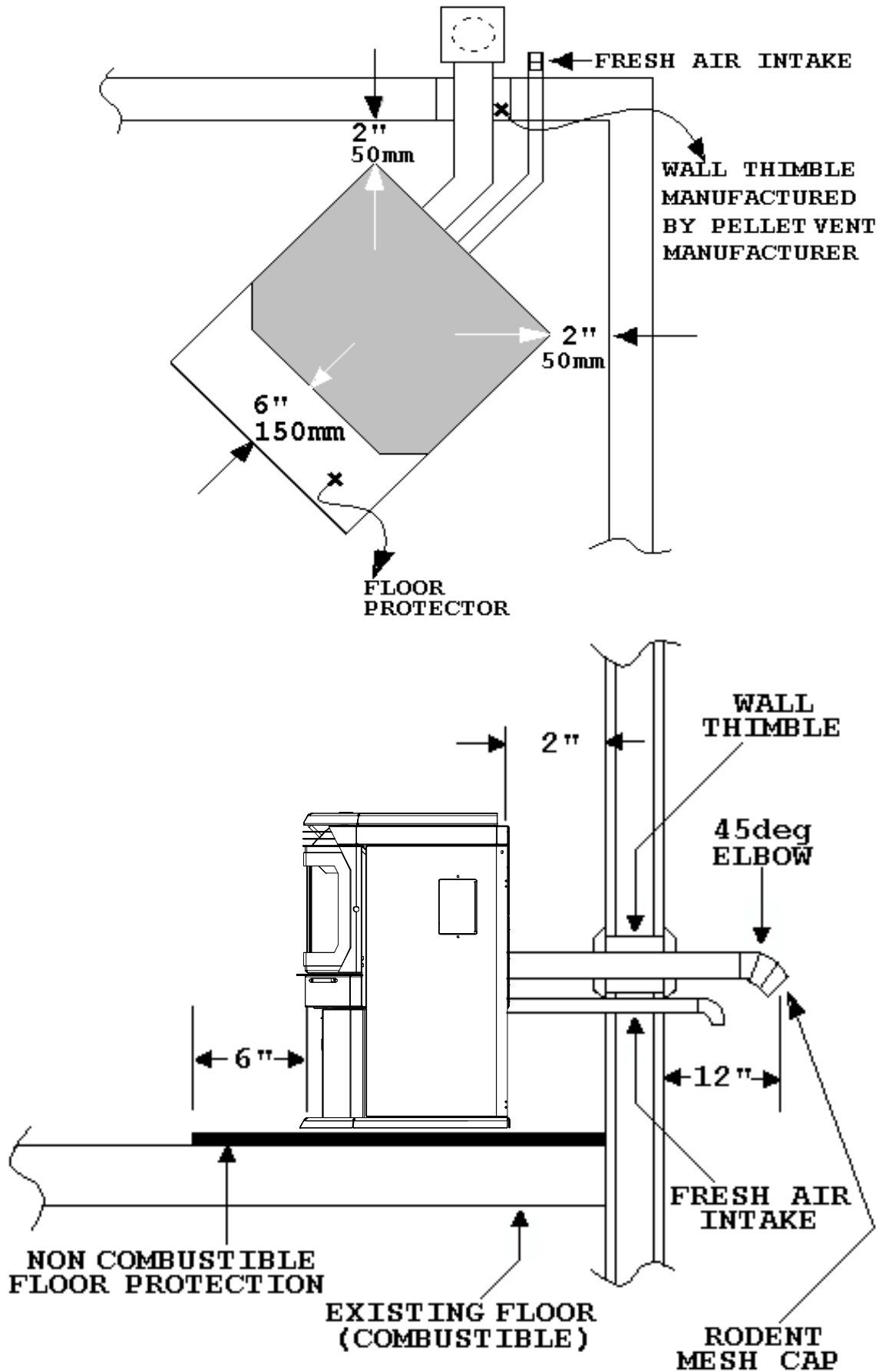

INSIDE VERTICAL THROUGH THE ROOF INSTALLATION,

1. Choose a stove location that is ideal. See the section Deciding Where to Locate Your Pellet Appliance.
2. Place a non-combustible hearth pad where necessary.
3. Place the unit on the hearth pad and space it in a manner so when the pellet vent is installed vertically, it will be 3" (76 mm) away from a combustible wall.
4. Locate the center of the fresh air intake pipe on the unit. Match that center with the same point on the wall and cut a hole about 1 5/8" (41 mm) in diameter.
5. Install the fresh air intake pipe.
6. Install the tee with clean out.
7. Install the pellet vent upward from there. When you reach the ceiling make sure that the vent goes through the ceiling firestop. Maintain a 3" (76 mm) distance to combustibles and keep attic insulation away from the pipe.
8. Finally, extend the pellet vent to go through the roof flashing.
9. Ensure that the rain cap is approximately 36" (900 mm) above the roof.

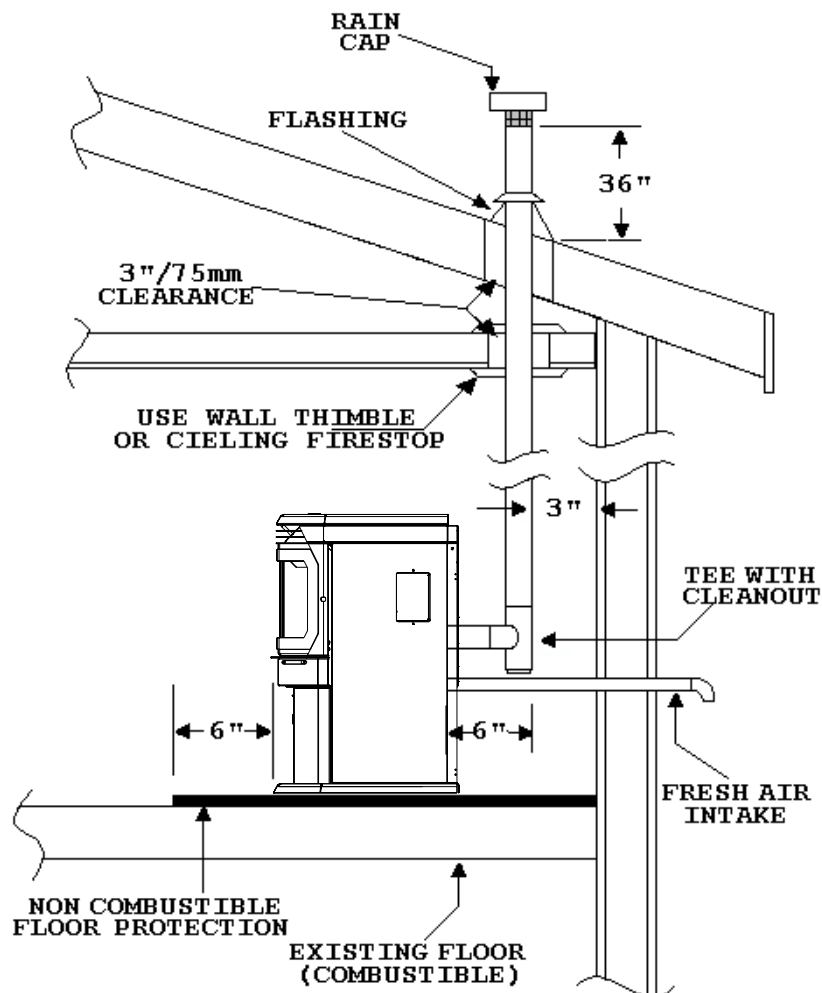

OUTSIDE VERTICAL PIPE INSTALLATION

To accomplish the above titled installation, follow steps 1 through 8 in the previous section and then finish it by performing the following.

9. Install a tee with clean out on the outside of the house.
10. Install PL vent upward from the tee. Make sure that you install support brackets to keep the vent straight and secure.
11. Secure the flashing as you go through the roof.
12. Ensure that the rain cap is approximately 36" (900 mm) above the roof.

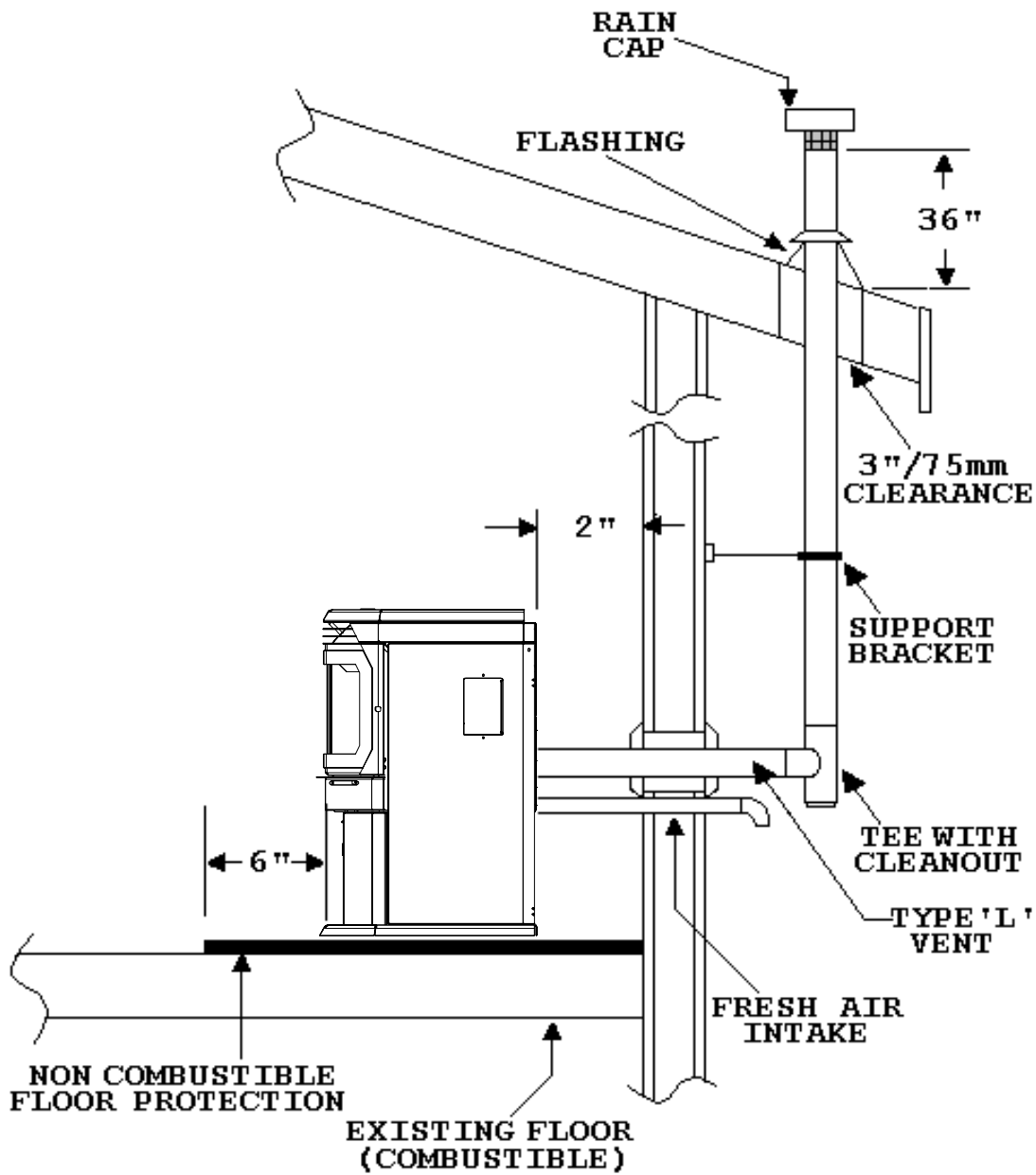

MOBILE HOME INSTALLATION

- Secure the heater to the floor using the two holes in the pedestal. Do not disturb the structural integrity of the home.
- Ensure the unit is electrically grounded to the chassis of your home (permanently).
- Do not install in a room people sleep in.
- Outside fresh air is mandatory.

OUTSIDE FRESH AIR CONNECTIONS

Outside fresh air is mandatory when installing this unit in airtight homes and mobile homes. When connecting to an outside fresh air source, do not use plastic, combustible pipe. Only 1 5/8" ID (inside diameter) steel, aluminum or copper pipe should be used. It is recommended, when you are installing a fresh air system, to keep the number of bends in the pipe to a minimum.

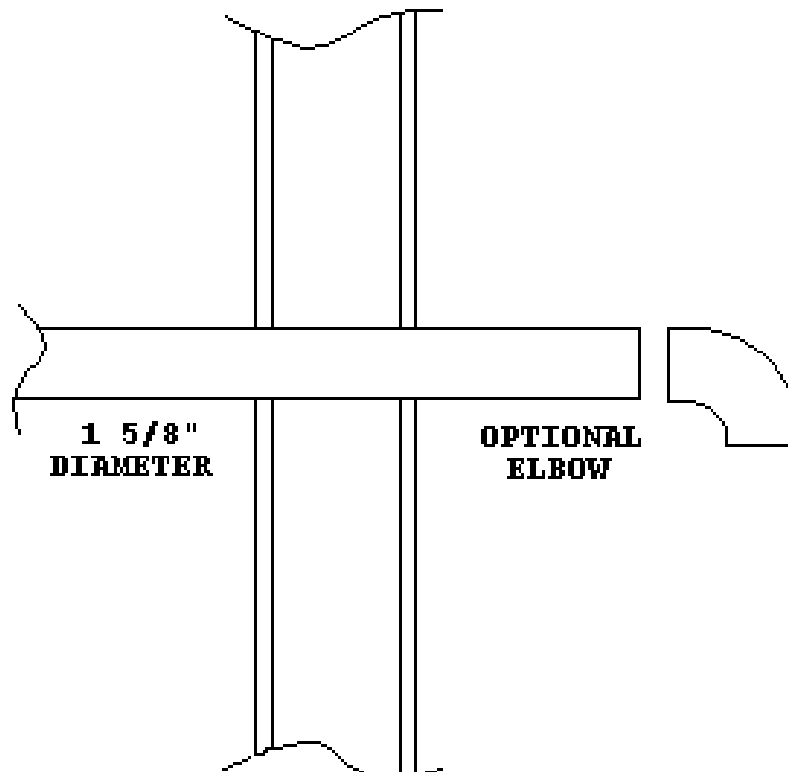

TROUBLESHOOTING:

DO NOT:

- Hold the start-up switch down, this is a momentary contact switch and can be damaged if held down too long.
- Service the stove with wet hands. The stove is an electrical appliance, which may pose a shock hazard if handled improperly. Only qualified technicians should deal with possible internal electrical failures.
- Remove any screws in the firebox without first lubricating them with penetrating oil.

What to do if:

1. The stove will not start
2. The stove will not operate when hot
3. The exhaust blower will not function normally
4. The convection blower will not function normally
5. Igniter : The pellets will not light.
6. The auger motor does not function normally
7. The Dial-A-Fire has no effect on the fire
8. The stove will not shut off
9. The stove keeps going out

***NOTE:** *All troubleshooting procedures should be carried out by qualified technicians or installers.*

1. The stove will not start

- Make sure the stove is plugged in and the wall outlet is supplying power.
- Push the Start-up switch, if the stove fails to start, unplug the unit and open the hinged side panels (held tight with one screw at the top, front).
- With the stove unplugged, examine all connections. Make sure they are firmly connected and that there are no exposed wires touching the stove (except the chassis ground wire).
- Check the continuity and placement of connections against the diagram in the back of this manual.
- Ensure that the connections to the (15) minute start-up timer are correct.
- Attempt to bypass the switch by inserting a jumper wire between the red and white wires that attach to the switch. Plug the stove back in. If the stove starts, replace the switch.
- If this fails, replace the (15) minute start-up timer.

The stove will not operate when hot

- Unplug the stove, open the left side panel. Jump the two brown leads that are attached to the 120°F (49°C) Exhaust temperature sensor. If the stove operates replace the 120°F (49°C) sensor.

2. The exhaust motor will not function normally

- Open the left side panel, check all connections against the wiring diagram.
- Thoroughly check for broken wires or connections.
- If all the connections are verified and the exhaust blower does not function at all, tap lightly on the exhaust blower's motor end cap, this may loosen a tight motor.
- Apply 115 V directly to the exhaust blower. If the motor does not run, replace the blower.
- If the motor runs, check the exhaust potentiometer in the Dial A Fire. Remove the grey wires from the exhaust motor speed controller and measure the resistance (10 ohms. to 400k ohms). If this range is not present or it is an open circuit Replace the speed controller.
- Check all wires for continuity
- Replace the exhaust motor phase control (speed control module).

3. The convection blower will not function normally

- Check all the connections between the controller, switch, and the convection blower against the wiring diagram.
- If the convection motor will not run, apply 115 V to the motor directly. If the motor runs, replace the fan controller. If the motor does not run, the convection blower has failed. Replace the blower.
- If the convection blower runs on high at all times (no control with the fan controller), check the connections from the 160°F (71°C) sensor (located on the upper left side of the firewall) and convection fan controller to the blower. Disconnect one of the wires from the sensor, if control of the convection blower returns to the fan controller, replace the sensor.
- If the motor is still on high, re-connect the sensor and replace the convection fan controller.

5. Igniter- the pellets will not light

Everything else in the stove operates but the igniter will not light the pellets

- Make sure the burnpot liner is up tight and square to the ignitor tube.
- Check to see if the exhaust blower is operating.
- Check all the electrical connections on the 120°F (49°C) temperature sensor located on the exhaust channel.
- Check the connections at the igniter socket.
- Place a jumper wire between the two leads on the 120°F (49°C) temperature sensor. If the igniter works. **Replace the sensor.**
- If the igniter does not work. **Replace the igniter**

NOTE: The igniter should be bright orange in color. If not Replace the igniter.

6. The auger motor will not function normally

- Make sure the exhaust blower is operating.
- Make sure the dial-a-fire is turned on.
- Unplug the stove and open the side and back panels.
- Check all the connections to the auger motor, auger dial-a-fire, vacuum sensor, 200°F (93°C) temperature sensor and the timing control module against the wiring diagram in this manual.
- Check the condition of the vacuum hose (located on the left side of the stove). It should not be cracked or torn and should be installed on the top air inlet tube on the vacuum sensor.
- Check the manual reset button on the 200°F (93°C) temperature sensor. If this sensor has been tripped, check for the cause of the over-heating before pushing the red button in. Check auger for movement.
- If the auger still does not work, then apply 115 V directly to the auger motor. If the auger motor does not work, replace it.
- By-pass the 200°F (93°C) temperature sensor with a jumper wire check the auger. If the auger works replace the sensor.
- Check the vacuum sensor by placing a jumper wire between the blue wires that are attached to the sensor. If the auger works, test to see if the exhaust blower is producing enough firebox vacuum.
- To test the exhaust vacuum place a magnehelic gauge in the sensor end of the vacuum tube. It should read 0.23" wc. If the reading is good then replace the vacuum sensor.
- If the auger motor still does not work, then attempt to by-pass the auger dial-a-fire control by removing the leads from the timing control module's second delay pins and placing a jumper across the pins. If the auger now cycles very quickly, test the dial-a-fire potentiometer. If the auger did not cycle then replace the timing control module.
- To test the dial-a-fire potentiometer. The potentiometer should have a range of 34K to approximately 900 K ($\pm 10\%$), if the range is not close then replace the potentiometer. Check the voltage across the load pins of the timing module. It should be around 1-2 V, cycling to line voltage during an auger pulse. If not, replace the timing control module.

7. The dial-a-fire has no effect on the fire

- Make sure all connections to the timer control module are secure.
- Perform a resistance test to the dial-a-fire potentiometer, by placing the two test leads from a multimeter into the leads of the potentiometer. The potentiometer should have a range of 34K to approximately 900 K ($\pm 10\%$).

Potentiometer Readings:

Full counter-clockwise (switched off) = open circuit, overload or Infinite resistance

Low fire..... 800 K to 900 K

High fire 34 K to 40 K

If the range is not close or does not vary then replace the potentiometer.

8. The stove will not shut down

- Check the connections to the 120°F (49°C) exhaust temperature sensor, start-up switch and the start-up timer against the wiring diagram.
- Check the 120°F (49°C) temperature sensor by removing one of the brown wires from the sensor. The unit should shut down right away as long as the start button was not pressed within 15 minutes of this test. If the stove shuts down within 15 minutes, replace the 120°F (49°C) sensor. If the stove does not shut down within 15 minutes, test the switch.
- To test the switch, the stove must be cold. Pull the plug, then plug the stove back in. If it fails to start, Replace the switch.

9. The stove keeps going out

- If the stove goes out and leaves fresh unburned pellets or cigarette-like ashes in the burn pot liner, the fire is going out before the 120°F (49°C) temperature sensor shuts the stove off.
 - Check to see that the slider is in the correct position.
 - Turn the Dial-a-Fire up slightly (poor quality pellets will require slightly higher settings).
- If the stove goes out and there are partially burned pellets left in the burn pot liner, the stove shuts down due to a lack of air, exhaust temperature or power failure.
 - Adjust the slider damper.
 - Check to see if the stove needs a more complete cleaning.
 - Turn the Dial-a-Fire up slightly (poor quality pellets will require slightly higher settings).
 - Did the power go out?
- If the stove goes out and there are no pellets in the liner, the auger is stopping.
 - See “The auger motor will not function normally” and “The exhaust blower will not function normally.”

WIRING DIAGRAM

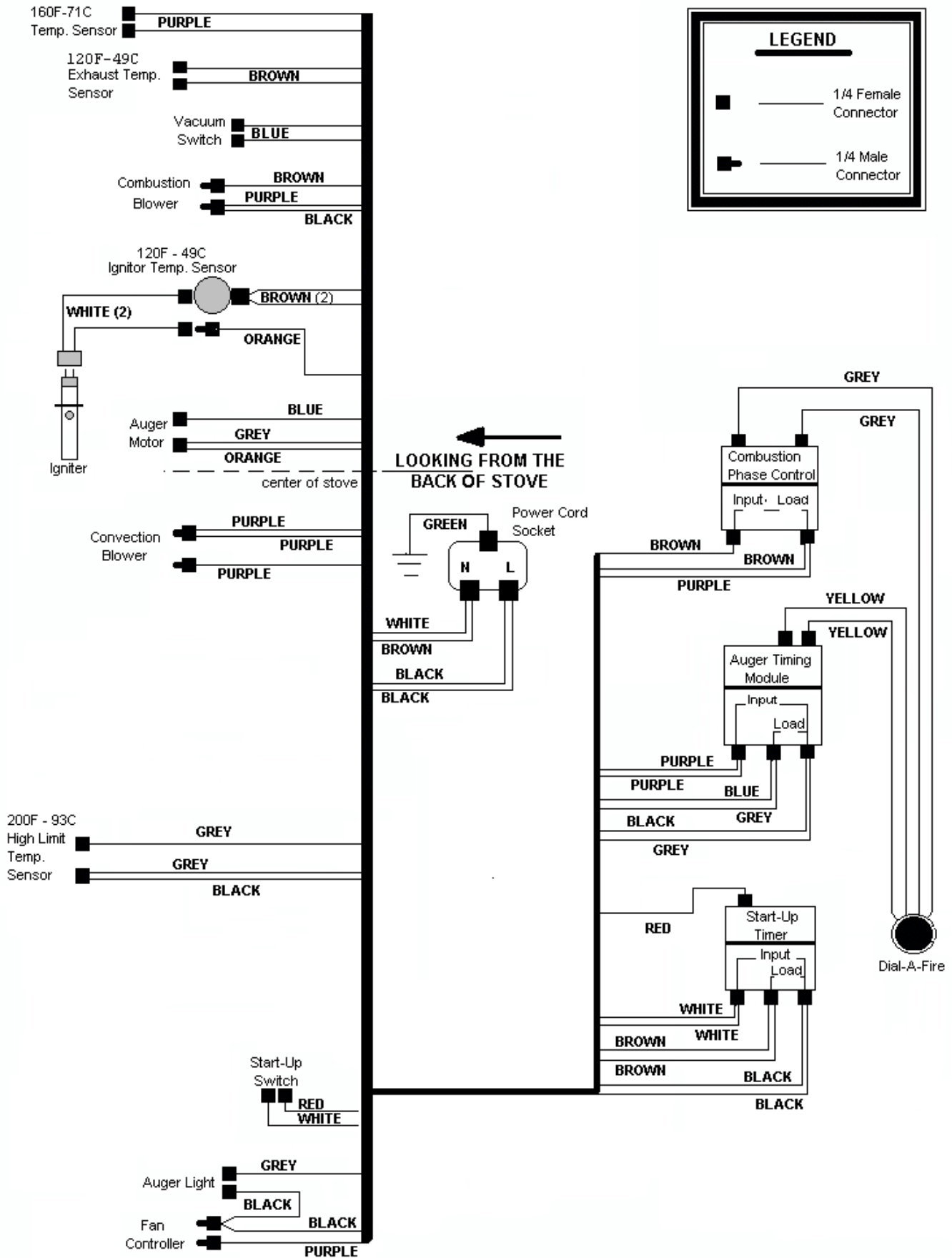

SOLUS PARTS LIST

EF4i-001	AUGER MOTOR	EF4i-124	SHOULDER BOLT, HRD BUSH, NUT
EF4i-002	CONVECTION BLOWER	EF4i-127	PIN IGNITER
EF4i-007	COMBUSTION BLOWER	EF4i-130	STEEL BRICK LINER
EF4i-008	COMBUSTION MAIN IMPELLER	50-316	SOLUS PEDESTAL
EF4i-009	COMBUSTION COOLING IMPELLER	EF4i-141	PHASE CONTROLLER
EF4i-010	EXHAUST TEMP SENSOR 120°F	50-315	SOLUS CABINET SIDE LEFT
EF4i-011	COMBUSTION MOUNTING GASKET	50-314	SOLUS CABINET SIDE RIGHT
EF4i-012	COMBUSTION BLOWER GASKET	EF4i-144	GOLD BARS SET (PIECES)
EF4i-013	FAN TEMP SENSOR 160° F	EF4i-152	THERMOSTAT INTERFACE
EF4i-015	IGNITION TEMP SENSOR 120° F	EF4i-211	TAPPED CORNER BRACKET
EF4i-016	HIGH LIMIT SENSOR 200° F MR.	20-017	FIREBOX LINER WOOL INSULATION
EF4i-017	VACUUM SWITCH	20-034	EF2/3/4 HALOGEN SOCKET
EF4i-021	IGNITION BURN POT	20-040	EF2/3/4 CONTROL PANEL DOOR
EF4i-024	SS BURN POT LINER	50-317	PEDESTAL PILLAR POSTS
50-319	AUGER	50-318	SOLUS MAGNET BRACKET
EF4i-026	AUGER BRASS BUSH AND PLATE	50-336	SOLUS ASH PAN
EF4i-028	DOOR HANDLE (wooden)		
EF4i-029	DOOR LATCH W/BOLT		
EF4i-36	AUGER TIMER CONTROL		
EF4i-037	POWER UP TIMER		
EF4i-041	GREEN LIGHT		
EF4i-043	START UP SWITCH		
EF4i-044	DIAL-A-FIRE		
EF4i-045	FAN CONTROLLER W/KNOB		
FE4i-047	FIREBOX LINER W/INSULATION		
EF4i-051	HEAT EXCHANGER ROD W/KNOB		
EF4i-053	CONTROL PANEL & DECAL		
EF4i-054	POWER CORD		
EF4i-055	ASH PAN GASKET 1/2 X 1/8" FLAT		
EF4i-056	DOOR GASKET 3/4" FIRM X 80"		
EF4i-058	WINDOW CHANNEL TAPE		
EF4i-060	ASH PAN LATCH		
EF4i-062	GLASS SET		
EF4i-063	SLIDER DAMPER SPACER		
EF4i-064	SLIDER DAMPER PLATE		
EF4i-065	AUGER BRASS BUSHINGS (SET of 2)		
EF4i-066	FIREBOX LINER TOP PLATE		
EF4i-069	AUGER COLLAR SCREW SET		
EF4i-071	WIRING HARNESS		
EF4i-088A	LOG SET		
EF4i-092	GOLD COMPLETE		
EF4i-093	GOLD DOOR ONLY		
EF4i-094	PAINTED DOOR COMPLETE		
EF4i-095	PAINTED DOOR ONLY		
EF4i-096	DOOR LATCH AND HINGE COVERS		
EF4i-097	BACK GRILL		
EF4i-103	ASH SILL		
EF4i-104	HOPPER LID		
EF4i-111	FS STOVE TOP		
	OWNERS MANUAL		

FROM

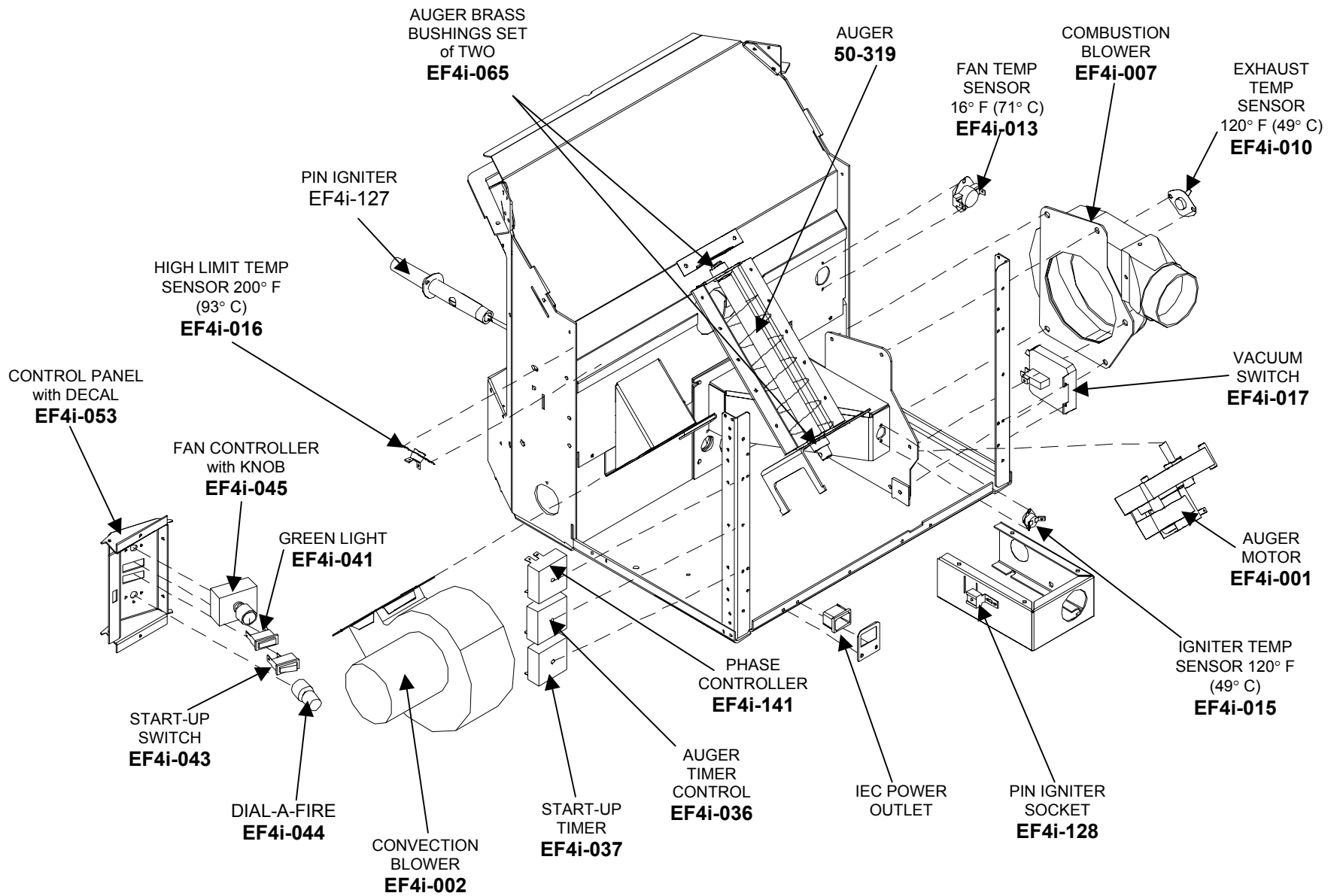

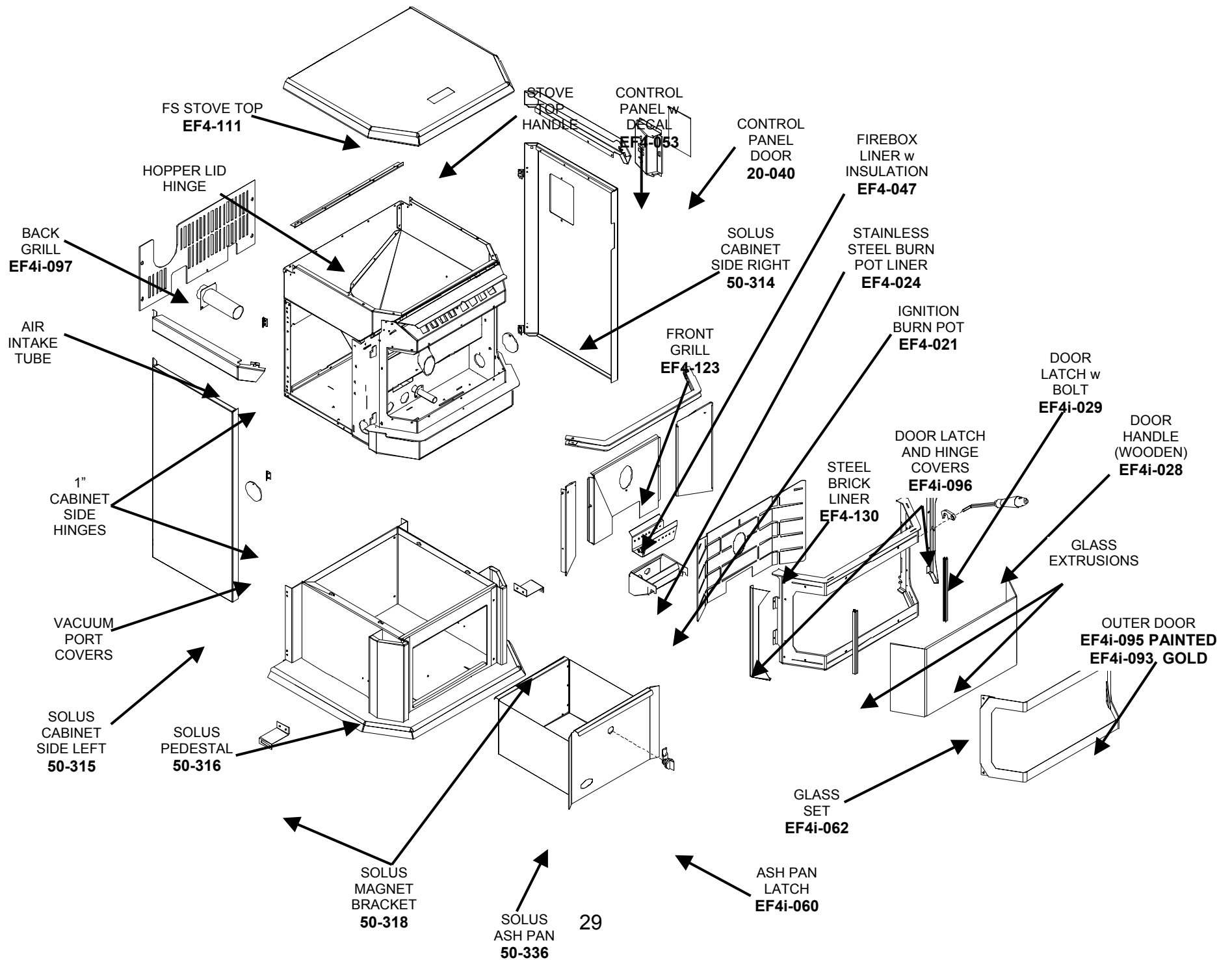

WARRANTY

Sherwood Industries Ltd. gives a five year limited warranty on all steel manufactured parts. A one-year warranty is provided on all electrical components. The above limited warranties are extended only to the original purchaser.

There is no warranty on the following parts:

- fiberglass rope baskets
- refractory material
- burn pot liner
- paint
- enamel finish or gold plating where it applies, and,
- vacuum hose.

****NOTE:** The paint on the brick firebox lining may peel, this is due to the extreme conditions applied to the paint and is in no way covered under warranty.

WHEN FILLING A WARRANTY CLAIM PLEASE COMPLETE THE FOLLOWING INFORMATION ON AN OFFICIAL WARRANTY CLAIM FORM:

TO THE DEALER:

- Name, Address and Telephone Number of purchaser and date of purchase.
- Date of Installation. Name of the installer and dealer. Serial Number of the appliance. Nature of the complaint, defects or malfunction, description and part # of any parts replaced.

TO THE DISTRIBUTOR:

- Sign and verify that work and information are correct.

ENSURE THAT YOU SPECIFY THE NATURE OF THE COMPLAINT, DEFECT, PERIODICAL MALFUNCTION, ETC.

The limited warranty covers defects in materials and workmanship as long as the products has been installed according to the manual's instruction. If the product is damaged or broken as a result of mishandling or misuse, the warranty does not apply. Removal and re-installation costs are not covered under this warranty.

It is the manufacturer's option whether to repair or replace the appliance. The shipping cost to and from the factory is paid by the consumer. All warranties by the manufacturer are set forth herein and no claim shall be made against the manufacturer on any oral warranty or representation.

Sherwood Industries Ltd. assumes no responsibility for damage caused by household power fluctuations or power surges.

Under Warranty

For the do-it-yourself Individual

The consumer should be aware that the pellet appliance needs setting using tools that he/she might not have. Consult an ENVIRO dealer. It is recommended than only an authorized ENVIRO dealer installs an ENVIRO unit. There will be no warranty coverage on parts destroyed or burnt out as a result of a consumer installation error or defect.

Sherwood Industries Ltd. reserves the right to make changes without any notice.

9/23/2002

WEB SITE ADDRESS (www.envirofire.biz)