



SHERWOOD INDUSTRIES IS AN ENVIRONMENTALLY RESPONSIBLE COMPANY **Warnock Hersey**
THIS MANUAL IS PRINTED ON RECYCLED PAPER

CH US



**WESTPORT
BEDFORD**

REAR-TOP VENT By: SHERWOOD INDUSTRIES LTD.

OWNERS MANUAL

PLEASE KEEP THESE INSTRUCTIONS FOR FUTURE REFERENCE

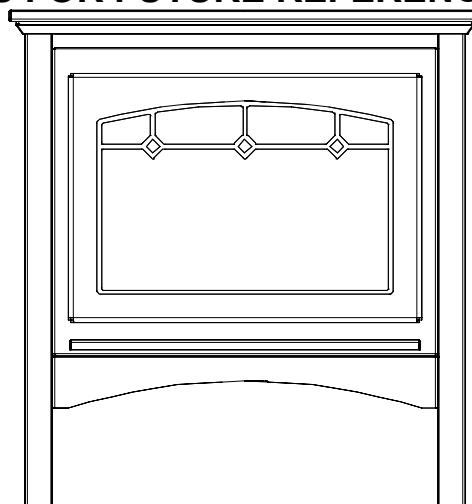
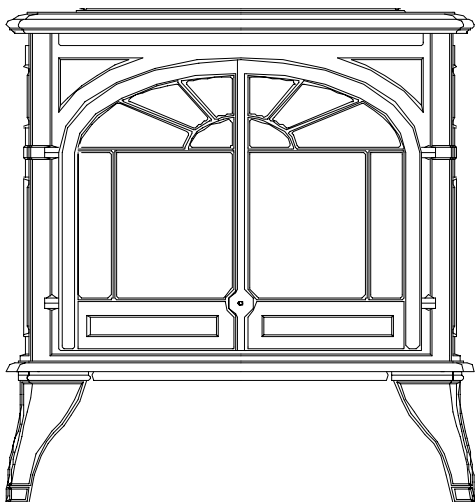

This appliance may be installed in an after market permanently located, manufactured (mobile) home, where not prohibited by local codes.

This appliance is only for use with the type of gas indicated on the rating plate. This appliance is not convertible for use with other gases, unless a certified kit is used.

WHAT TO DO IF YOU SMELL GAS

- Open windows/Extinguish any open flame
- Do not try to light any appliance.
- Do not touch any electrical switch; do not use any phone in your building.
- Immediately call your gas supplier from a neighbor's phone. Follow the gas supplier's instructions.
- If you cannot reach your gas supplier, call the fire department.

WARNING

If the information in this manual is not followed exactly, a fire or explosion may result causing property damage, personal injury or loss of life. Installation and service must be performed by a qualified installer, service agency or the gas supplier.

FOR YOUR SAFETY

Do not store or use gasoline or other Flammable vapors and liquids in the vicinity of this or any other appliance.

SAFETY PRECAUTIONS

FOR SAFE INSTALLATION AND OPERATION OF YOUR "ENVIROGAS" HEATER, PLEASE, CAREFULLY READ THE FOLLOWING INFORMATION:

- All "ENVIROGAS" gas-fired appliances must be installed in accordance with these instructions. Carefully read all the instructions in this manual first. Consult the building authority having jurisdiction to determine the need for a permit prior to commencing the installation.
- **NOTE** Failure to follow these instructions could cause a malfunction of the fireplace, which could result in death, serious bodily injury, and/or property damage.
- Failure to follow these instructions may also void your fire insurance and/or warranty.

GENERAL

- Installation and repair should be done by a qualified service person. The appliance should be inspected before use and at least annually by a qualified service person. More frequent cleaning may be required due to excessive lint from carpeting, bedding material, etc. It is imperative that control compartments, burners and circulating air passageways of the appliance be kept clean.
- Due to high temperatures the appliance should be located out of high traffic areas and away from furniture and draperies. Children and adults should be alerted to hazards of high surface temperatures and should stay away to avoid burns or clothing ignition.
- Young children should be carefully supervised when they are in the same room as the appliance.
- Clothing or other flammable material should not be placed on or near the appliance.

FOR YOUR SAFETY

- Installation and service must be performed by a qualified installer, service agency or the gas supplier.
- This installation must conform with local codes or, in the absence of local codes with the current CAN/CGA -B149 installation code in Canada or the National Fuel Gas Code ANSI Z223.1.2 in the USA.

- To prevent injury do not allow anyone who is unfamiliar with the operation to use the stove.

To prevent injury, if the pilot or pilot and burners have gone out on their own, open the glass door and wait 5 minutes to air out before attempting to re-light stove.

- Always keep the area around these appliances clear of combustible material, gasoline or other flammable vapors and liquids.
- These appliances should not be used as a drying rack for clothing or for hanging Christmas stockings or decorations.
- Due to the paint curing on the stove a faint odor and slight smoking will likely be noticed when the stove is first used. Open a window until the slight smoking stops.

Always connect this gas stove to a vent system and vent to the outside of the building envelope. Never vent to another room or inside a building. Make sure you use the vent pipe that is specified. Make sure that the vent is properly sized and is of adequate height to provide the proper draft. Inspect the venting system annually for blockage and any signs of deterioration.

WARNING: Failure to position the parts in accordance with these diagrams or failure to use only parts specifically approved with this appliance may result in property damage or personal injury.
WARNING: Do not operate with the glass front removed, cracked or broken. Replacement of the glass should be done by a licensed or qualified service person.

- Never use solid fuels such as wood, paper, cardboard, coal, or any other flammable liquids etc., in this appliance.
- Do not use this heater if any part has been under water. Immediately call a qualified service technician to inspect the heater and to replace any part of the control system and any gas control which has been under water.
- Do not abuse glass by striking or slamming door shut

TABLE OF CONTENTS

SECTION		PAGE
1.	Code Approvals	3
2.	Dimensions and Clearances to Combustibles	4
3.	Venting	4-17
	Vent restrictor settings	17-18
4.	Electrical Requirements	19
5.	Gas Line Connection and Testing	20
6.	Installation of Log Sets and Embers	21
7.	Operating Instructions	22
8.	Routine Maintenance and Service / Electronic ignition module	23
9.	Fuel Conversions	24
10.	Trouble Shooting	25
11.	Warranty	26
12.	Parts list	27
13.	Installation Data Sheet	28

CODES AND APPROVALS

DIRECT VENT Type is identified by the suffix **DV**. This type of appliance draws all of its air for combustion from outside of the dwelling through specially designed vent pipe system.

**** TOP VENT DV ****

Certified for installation from 0-4500ft (0-1372 m)

**** REAR VENT SEE PAGE 13****

Certified for installation from 0-2000ft (0-610 m)

- These appliances have been tested by INTERTEK TESTING SERVICES (**WH**) and found to comply with the established standards VENTED GAS FIREPLACE HEATER in CANADA and the USA as follows:

<p>VENTED GAS FIREPLACE HEATER (<i>WESTPORT / BEDFORD DV</i>) (NG / LPG) TESTED TO: ANSI Z21.88.1998 CSA 2.33.M98 VENTED GAS FIREPLACE HEATER CSA 2.17 GAS FIRED APPLIANCES FOR HIGH ALTITUDE.</p>

ENVIROGAS *WESTPORT / BEDFORD*

- Has been certified for use with either natural or propane gases. (see rating label.)
- Is not for use with solid fuels.
- Is approved for bedroom or bed sitting room. (Canada must install an approved wall thermostat)
- Must be installed in accordance with local codes.
If none exist use current installation code CAN/CGA B149 in Canada or ANSI Z223.1/NFPA 54 in the USA.
- Must be properly connected to a venting system and not connected to a chimney flue serving a separate solid-fuel burning appliance.

DIMENSIONS AND CLEARANCES TO COMBUSTIBLES

WESTPORT

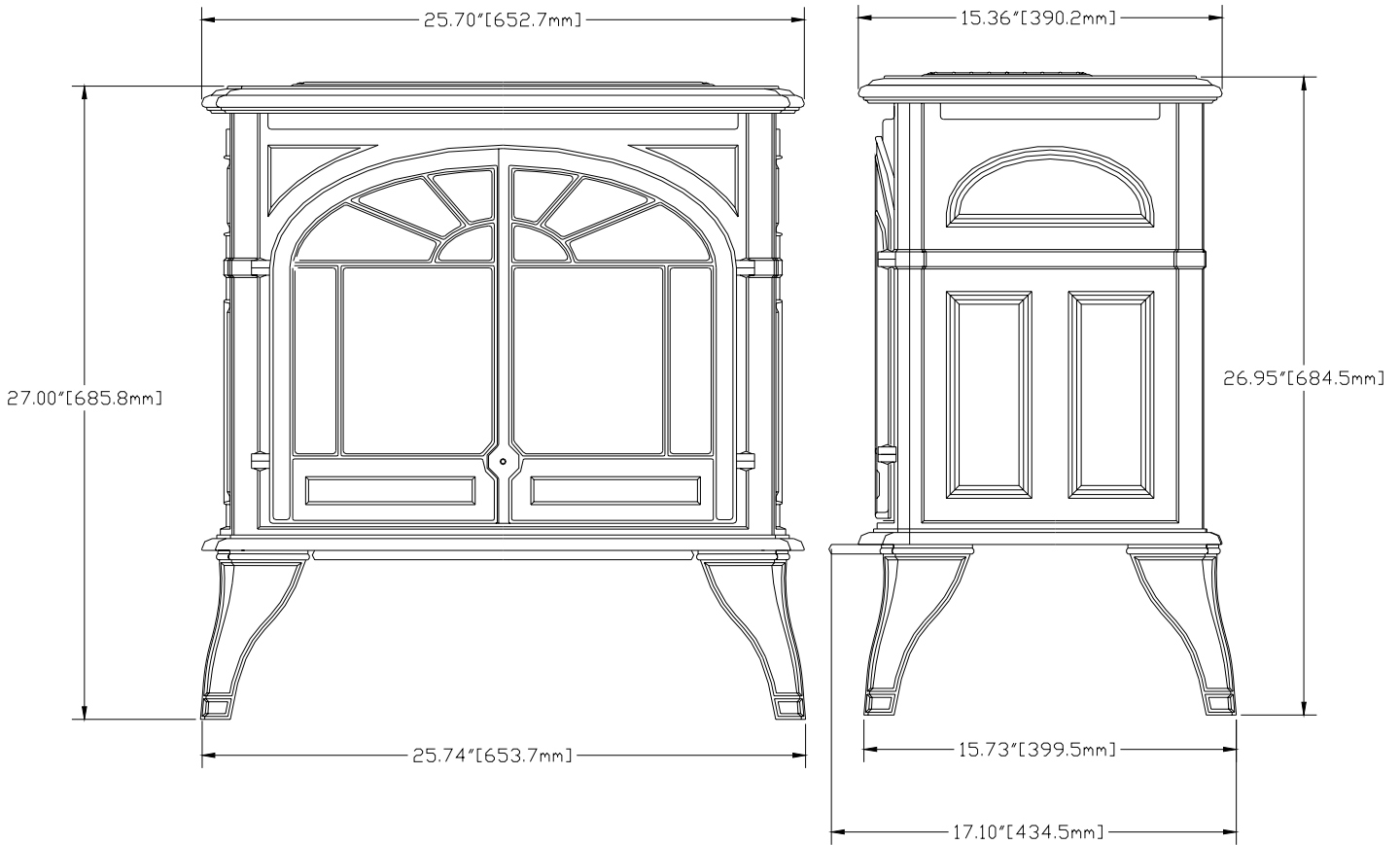

UNIT DIMENSIONS

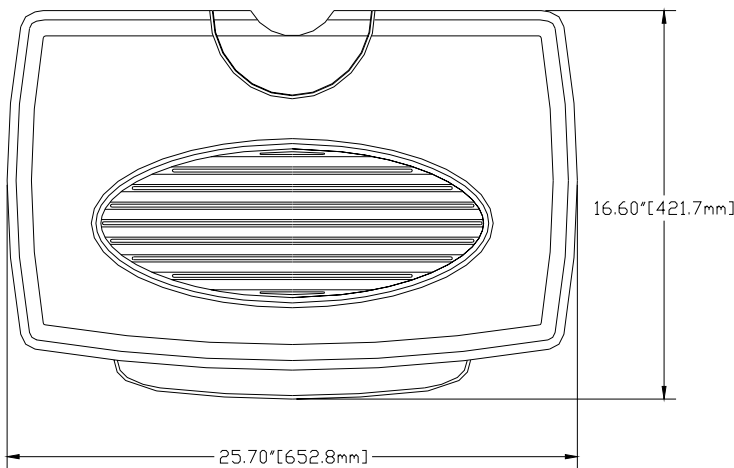

Height	27 inches	(68.5 cm)
Width	25.7 inches	(65.2 cm)
Depth	19.6 inches (49.78 cm)

Center to flue REAR VENT 24.5" (62.23cm)

CLEARANCES TO COMBUSTIBLES

Sidewall to unit	11 inches	(27.9 cm)
Backwall to unit	2.5 inches	(6.35 cm)
Corner to unit	2.5 inches	(6.35 cm)
Cieling	60 inches above floor	(152.4 cm)
Floor (hard wood and linoleum)	0 inches	
Carpeted surfaces must use a non combustible hearth pad.		

ALCOVE; Width 48 inches (121.9 cm)
 Depth 24 inches (60.96 cm)
 Height 60 inches (152.4 cm)

VENTING

WARNING: Operation of this heater when not connected to a properly installed and maintained venting system or tampering with the vent safety shutoff system can result in carbon monoxide (CO) poisoning and possible death.

DIMENSIONS AND CLEARANCES TO COMBUSTIBLES

BEDFORD

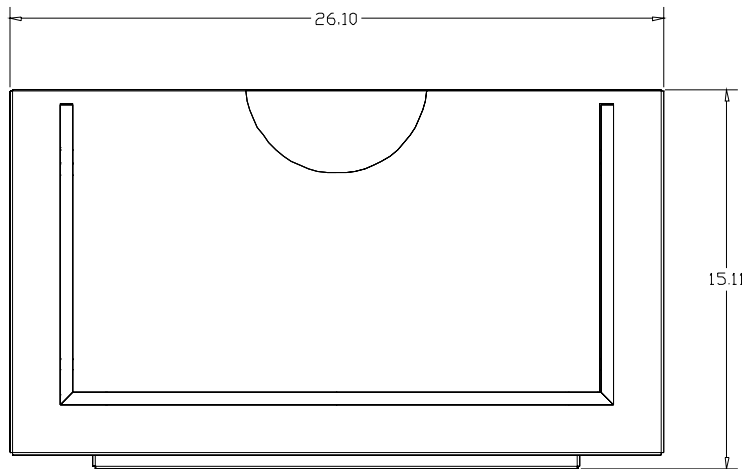
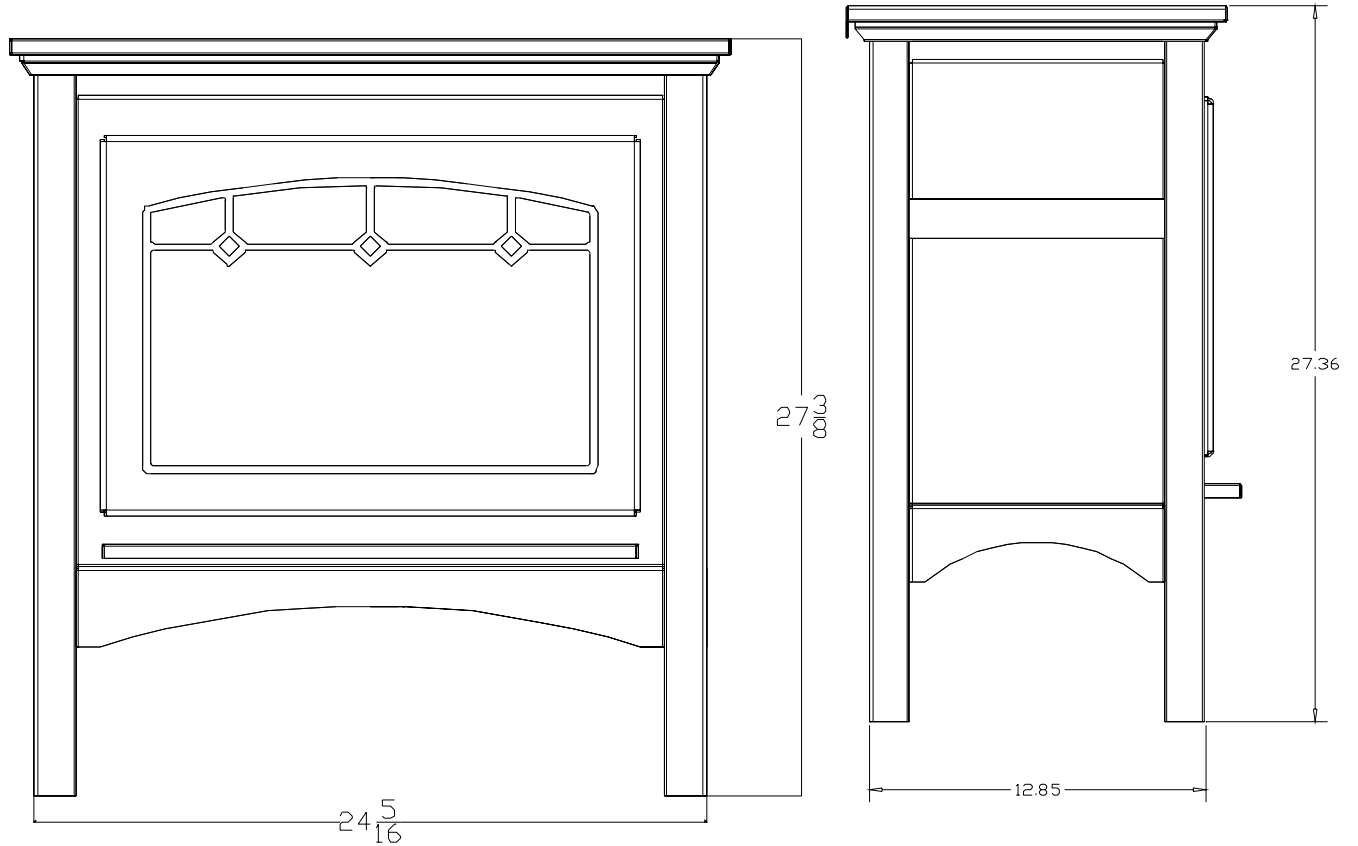

UNIT DIMENSIONS

Height	27 3/8 inches	(69.4 cm)
Width	26.1 inches	(66.29 cm)
Depth	15.11 inches	(38.38 cm)

Center to Flue REAR VENT 23.5" (59.69cm)

CLEARANCES TO COMBUSTIBLES

Sidewall to unit	11 inches	(27.9 cm)
Backwall to unit	2.5 inches	(6.35 cm)
Corner to unit	2.5 inches	(6.35 cm)
Cieling	60 inches above floor (152.4 cm)	
Floor	(hard wood and linoleum) 0 inches	

Carpeted surfaces must use a non combustible hearth pad.

ALCOVE; Width 48 inches (121.9 cm)
 Depth 24 inches (60.96 cm)
 Height 60 inches (152.4 cm)

VENTING

WARNING: Operation of this heater when not connected to a properly installed and maintained venting system or tampering with the vent safety shutoff system can result in carbon monoxide (CO) poisoning and possible death.

VENT TERMINAL CLEARANCES

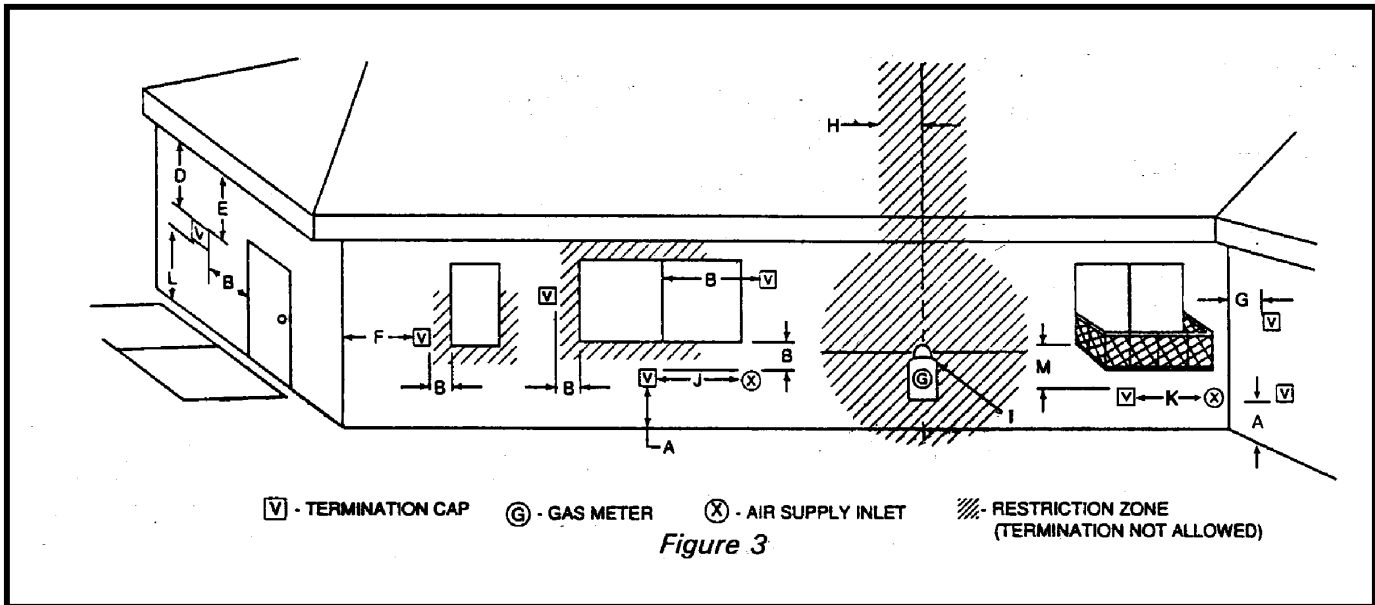

- A= Clearance above grade, verandah, porch, deck, or balcony [*12 inches (30 cm) minimum]
- B= Clearance to window or door that may be opened
[*12 inches (30 cm) minimum]
- C= Clearance to permanently closed window [minimum 12 inches (30 cm) recommended to prevent condensation on window]
- D= Vertical clearance to ventilated soffit located above the terminal within a horizontal distance of 2 feet (60 cm) from the center-line of the terminal (24 inches (60 cm) minimum)
- E= Clearance to unventilated soffit
[18 inches (45 cm) minimum]
- F= Clearance to outside corner [12 inches minimum]
- G= Clearance to inside corner [12 inches minimum]
- H=* Not to be installed above a meter/regulator assembly within 3 feet (90 cm) horizontally from the center-line of the regulator
- I= Clearance to service regulator vent outlet
[*6 feet (1.8m) minimum]
- J= Clearance to non-mechanical air supply inlet to building or the combustion air inlet to any other appliance
[12 inches (30 cm) minimum]
- K= Clearance to a mechanical air supply inlet
[*6 feet (1.8m) minimum]
- L=*** Clearance above paved side-walk or paved driveway located on public property
[*7 feet (2.1m) minimum]
- M= Clearance under verandah, porch, deck, or balcony [*24 inches (60 cm) minimum **]

*** A vent shall not terminate directly above a sidewalk or paved driveway, which is located between two single family dwellings and serves both dwelling

** Only permitted if verandah, porch, deck, or balcony is fully open on a minimum of 2 sides beneath the floor As specified in CGA B149 Installation Codes (1991) Note: Local Codes or Regulations may require different clearances

NOTE: Venting terminals shall not be recessed into walls or siding.

These models have been tested and certified for use with **SIMPSON DURAVENT DIRECT VENT TYPE "GS" PIPE FOR GAS STOVES, SECURITY CHIMNEYS "SECURE VENT DIRECT VENT SYSTEM"** Kits are available for vertical venting or horizontal venting. It is recommended that a bead of RTV High Temperature Silicone be applied to each outer vent joint and milpac to each inner joint before installation.

This model has also been tested for horizontal venting installations when using **SHERWOOD INDUSTRIES LTD.** horizontal venting kit **PART # EG 40-500**

SHERWOOD INDUSTRIES LTD PARTS:

- | | | | |
|---|------------------------------------------|----|-----------------------------------|
| 1 | Horizontal direct vent termination cap | 4 | Spring spacers |
| 1 | Flue collar adapter 5" tall (4 T20 Torx) | 3 | Decorative brass rings |
| 1 | Wall thimble | 1 | 4oz tube RTV silicone |
| 1 | Inside finish trim collar | 1 | 4oz can charcoal gray spray paint |
| 1 | 5' length of 4" double walled flex pipe | 20 | 9/16" tech screw |
| 2 | 24" sections 6 5/8' straight pipe | 8 | 1 1/2" wood screws |
| 1 | 6 5/8" 90° elbow | 1 | Vinyl siding deflector |

A MINIMUM VERTICAL LENGTH OF 24" TO THE FIRST 90 DEGREE ELBOW IS REQUIRED. WITH THIS MINIMUM VERTICAL RISE, HORIZONTAL RUNS OF FROM ONE TO THREE FEET ARE PERMITTED TO REACH THE OUTSIDE VENT TERMINATION. BEFORE BEGINNING THE INSTALLATION TAKE CARE TO ENSURE AN APPROPRIATE OUTSIDE LOCATION FOR THE VENT TERMINATION CAN BE ACCOMMODATED. **FOLLOW THE VENT LENGTH DIAGRAM PRECISELY.**

VENTING TERMINALS CANNOT BE RECESSED INTO A WALL OR SIDING.

If extra elbows are being used, overall allowable length will be reduced by 3 ft. per additional elbow

SIMPSON DURAVENT PARTS

<u>Number</u>	<u>Description</u>	<u>Number</u>	<u>Description</u>
908B	6" Pipe Length, Black	943S	Flashing, 7/12 to 12/12 Roof Pitch
907B	9" Pipe Length, Black	953	Storm Collar
906 (B)	12" Pipe Length, (Black)	963	Ceiling Fire stop
904 (B)	24" Pipe Length, (Black)	988	Wall Strap
903 (B)	36" Pipe Length, (Black)	984	Horizontal Square Termination
902 (B)	48" Pipe Length, (Black)	985	High Wind Horizontal Termination
911 (B)	11" to 14-5/8" Pipe , Adjustable, Black	980	Vertical Termination
945 (B)	45° Elbow, (Black)	991	High Wind Vertical Termination
990 (B)	90° Elbow, (Black)	950	Vinyl Siding Standoff
940	Round Support / Wall Thimble Cover	942	Wall Thimble
941	Cathedral Ceiling Support Box	971	Horizontal Termination Kit A
943	Flashing, 0/12 to 6/12 Roof Pitch		

Add suffix (B) for optional black parts as listed.

PLANNING YOUR INSTALLATION

There are two basic types of Direct Vent System installations. The two types of installations are:

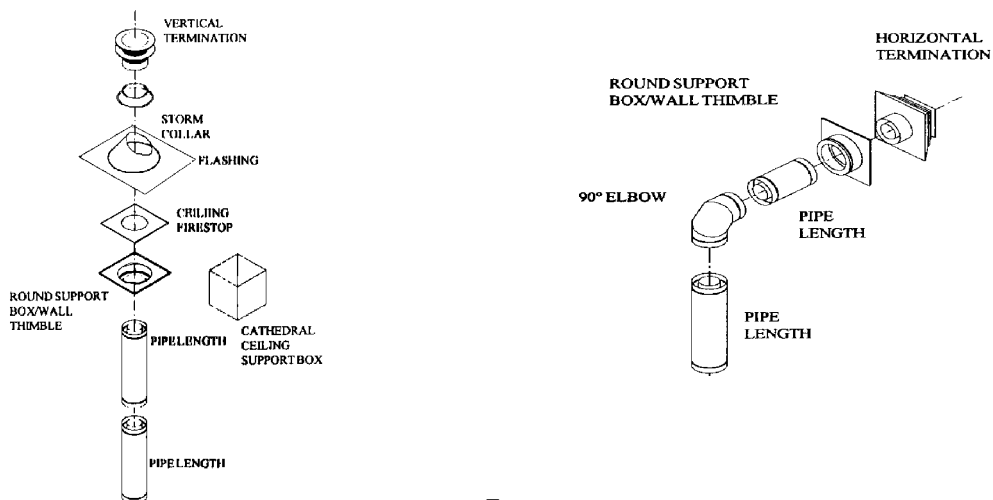

When planning your installation, it will be necessary to select the proper length of vent pipe for your particular requirements. It is important to note when passing through a wall, the maximum allowable wall thickness is 10-inches (254 mm), 1 ½ inches clearance to combustibles must be maintained. Select the amount of vertical rise desired for “vertical-to-horizontal” type installations. To determine the length of vent pipe required for vertical installations, measure the distance from the appliance flue outlet to the ceiling, the ceiling thickness, the vertical rise through the attic or second story, and allow for sufficient vent height above the roofline. For two story applications, A fire stop is required at each floor level. If an offset is needed in the attic, additional pipe and elbows will be required. To connect the venting system to the appliance flue outlet, a twist-lock adapter is built into the appliance at the factory.

HORIZONTAL INSTALLATION

STEP 1. Set the appliance in the desired location. Check to determine if wall studs or roof rafters are in the way when the venting system is attached. If this is the case, you may want to adjust the location of the appliance.

STEP 2. Direct vent pipe and fittings are designed with special twist-lock connections. Assemble the desired combination of black pipe and elbows to the appliance adapter with pipe seams oriented towards the wall or floor, as much out of view as possible.

Place a bead of Mil-Pac on the outer edge of the inner exhaust pipe (non-flared end). Place a bead of high temperature silicone on the male edge of the outer pipe. Push the pipe sections completely together, then twist-lock one section clockwise approximately one-quarter turn, until the two sections are fully locked. The female locking lugs will not be visible from the outside, on black pipe. They may be located by examining the inside of the female ends as shown in FIG-10.

NOTE:

(1) Twist-lock procedure: four indentations, located on the female end of the pipes and fittings, are designed to slide straight onto the male ends of adjacent pipes and fittings, by orienting the four pipe indentations so they match and slide into the four entry slots on the male end.

(2) Horizontal runs of vent pipe must be supported every three feet. Wall straps are available for this purpose.

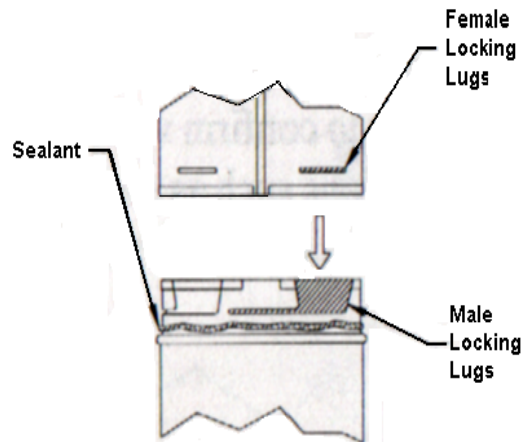

FIG. 10

STEP 3. With the pipe attached to the stove into the correct location, mark the wall for a 10 inch x 10 inch square hole. The center of the square hole should match the centerline of the horizontal pipe. Cut and frame the 10-inch x 10-inch hole in the exterior wall where the vent will be terminated. If the wall being penetrated is constructed of non-combustible material i.e. masonry or concrete, a 7-inch hole is acceptable.

STEP 4. Position the horizontal vent termination in the center of the 10-inch square hole, and attach to the exterior wall with the four screws provided. Before attaching the Vent Termination to the exterior wall, run a bead of non-hardening mastic around the edges, so as to make a seal between the termination and the wall. The arrow on the vent termination should be pointing up, insure that the proper clearances to combustible materials are maintained.

STEP 5. Before connecting the horizontal run of the vent pipe to the vent termination, slide the black decorative wall thimble cover over the vent pipe.

STEP 6. Slide the appliance and vent assembly towards the wall, carefully inserting the vent pipe into the cap assembly. It is important that the vent pipe extend into the vent cap a sufficient distance with a minimum of 1 ¼inch overlap. Secure the connection between the vent cap pipe and the vent cap by attaching the two sheet metal straps extending from the vent cap assembly into the outer wall of the vent pipe. Use the two sheet metal screws provided to connect the straps to the vent pipe. Bend any remaining portion of the sheet metal straps back towards the vent cap, so the decorative wall thimble FIG-13 will conceal it.

STEP 7. Slide the decorative wall thimble up to the wall surface and attach with the screws provided. Apply decorative brass or chrome trim if desired. FIG-14.

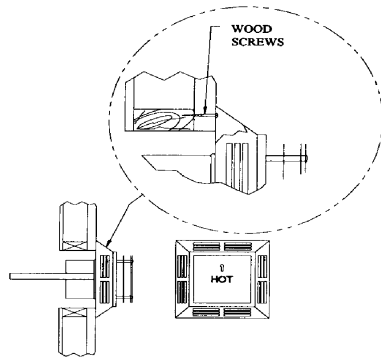

FIG. 11

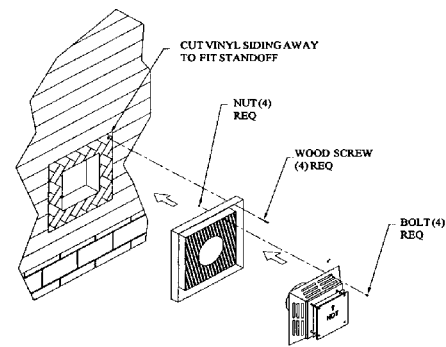

FIG. 12

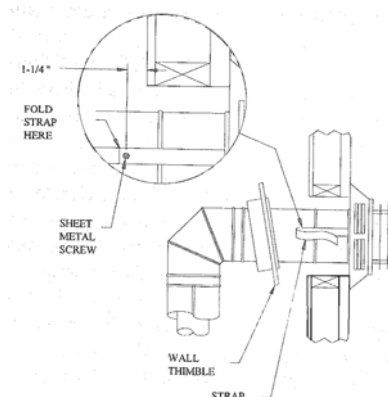

FIG-13

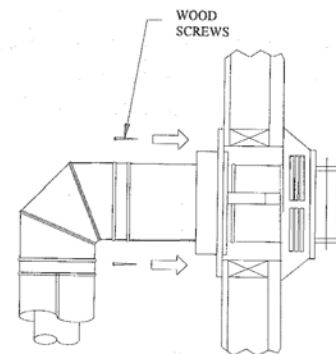

FIG-14

NOTES: (1) The four wood screws provided should be replaced with the appropriate fasteners for stucco, brick, concrete, or other types of siding.

(2) For buildings with vinyl siding, a vinyl siding standoff (950), should be installed between the vent cap and the exterior wall FIG-12. Attach the vinyl siding standoff to the horizontal termination. The vinyl siding standoff prevents excessive heat from possibly melting the vinyl siding material. Note that the horizontal vent termination bolts onto the flat portion of the vinyl siding standoff. (shaded area in FIG-12), so that an air space will exist between the wall and the vent termination.

NOTES: (1) The horizontal run of vent pipe must be level and **should have a 1/4 inch rise for every one foot of run towards the termination.** Never allow the vent to run downward. This could cause high temperature and may present the possibility of a fire.

(2) The location of the horizontal vent termination on the exterior wall must not be easily blocked or obstructed. Termination clearances are as follows:

(3) When installing a vent pipe in a chase the minimum clearance to combustibles is 4" inches (100 mm).

VERTICAL INSTALLATION

- STEP 1.** Check the instructions for required clearances (air spaces) to combustibles when passing through ceilings, walls, roofs, enclosures, attic rafters, or other nearby combustible surfaces. Do not pack air spaces with insulation.
- STEP 2.** Set the gas appliance in the desired location. Drop a plumb bob down from the ceiling to the position of the appliance flue exit, and mark the location where the vent will penetrate the ceiling. Drill a small hole at this point. Next, drop a plumb bob from the roof to the hole previously drilled in the ceiling, mark the spot where the vent will penetrate the roof. Determine if ceiling joists, roof rafters, or other framing will obstruct the venting system. You may wish to relocate the appliance, or to offset, to avoid cutting load bearing members.
- STEP 3.** To install the Round Support Box/Wall Thimble in a flat ceiling, cut a 10- inch square hole in the ceiling, centered in the hole drilled in Step 2. Frame the hole as shown in FIG-16.
- STEP 4.** Assemble the desired lengths of black pipe and elbows necessary to reach from the appliance adapter up through the Round Support Box. Insure that all pipe and elbow connections are in their fully twist-locked position.
- STEP 5.** Cut hole in the roof centered on the small hole placed in the roof from Step 2. The hole should be of sufficient size to meet minimum requirements for Clearance to Combustibles, as specified. Continue to assemble lengths of pipe and elbows necessary to reach from the ceiling Support Box up through the roofline. Galvanized pipe and elbows may be utilized in the attic, as well as above the roofline. The galvanized finish is desirable above the roofline, due to the higher corrosion resistance.
- STEP 6.** Once the pipe sections have been joined, and run up through the hole in the roof, slip an elbow strap (Part-989) over the exposed sections, bend the support straps outwards, and push the Elbow Strap down to the roof level, as shown in FIG 17. Tighten the clamp around the Pipe section. Use a level to make sure the pipe is truly vertical. With roofing nails, secure the support straps to the roof. Seal the nails holes heads with non-hardening mastic. Trim the excess length of the support straps that extend out beyond the edge of the flashing.
- STEP 7.** Slip the flashing over the pipe section protruding through the roof. Secure the base of the flashing to the roof with roofing nails. Use a non-hardening sealant between the uphill edge of the flashing and the roof. Insure the roofing material overlaps the top edge of the flashing as shown in FIG 17. Verify that you have at least the minimum clearance to combustibles at the roofline.
- STEP 8.** Continue to add pipe sections until the height of the vent cap meets the minimum code requirements. FIG 22. Note that for steep roof pitches, the vent height must be increased. In high wind conditions, nearby trees, adjoining roof lines, steep pitched roofs, and other similar factors can result in poor draft, or down drafting. In these cases, increasing the vent height may solve the problem.
- STEP 9.** Slip the Storm Collar over the pipe, and push it down to the top of the roof flashing as shown in FIG 17. Use the non-hardening sealant around the joint between the pipe and the Storm Collar.
- STEP 10.** Twist lock the vent cap.

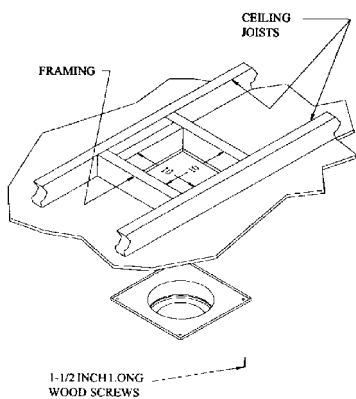

FIG-16

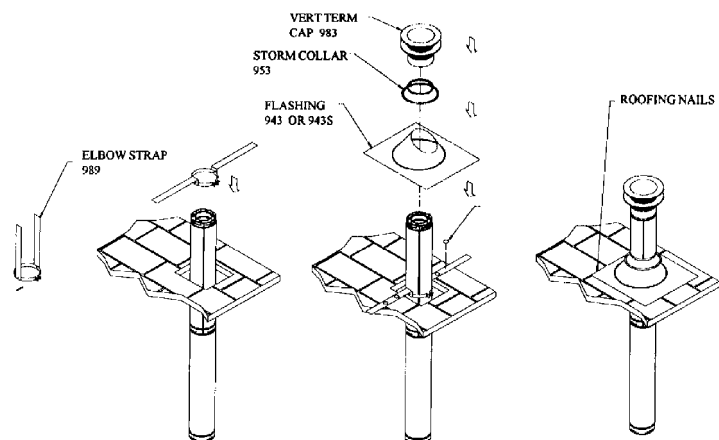

FIG-17

NOTES:

(1) If an offset is necessary in the attic to avoid obstructions, it is important to support the vent pipe every 3 feet, to avoid excessive stress on the elbows, and possible separation. Wall straps are available for this purpose. FIG-18

(2) When ever possible, use 45° degree elbows instead of 90° degree elbows. The 45° degree elbow offers less restriction to the flow of flue gases and intake air.

NOTES:

(1) For multi story installations. A ceiling firestop (part 963) is required at the second floor, and any subsequent floors. FIG-19. The opening should be framed to 10-inch x 10-inch inside dimensions, in the same manner as shown in FIG-16.

(2) Any occupied areas above the first floor, including closets and storage spaces, which the vertical vent passes through, must be enclosed. The enclosure may be framed and sheetrocked with standard building materials. However consult the appliance manufactures installation instructions for the minimum allowable clearance between the outside of the vent pipe, and the combustible surfaces of the enclosure. Do not fill any required air spaces with insulation.

FIG. 18

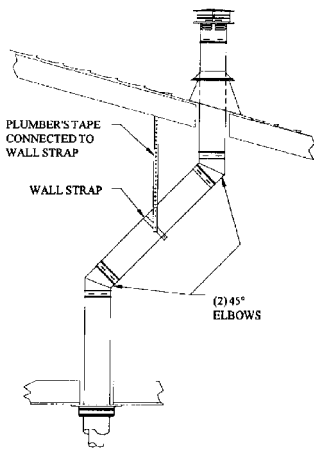

FIG.19

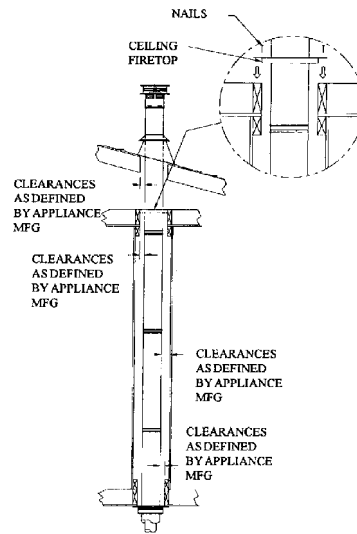

FIG.20

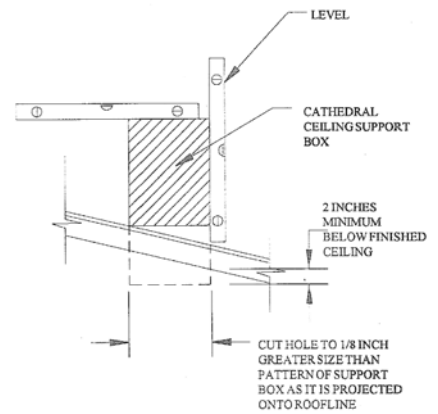

FIG-21

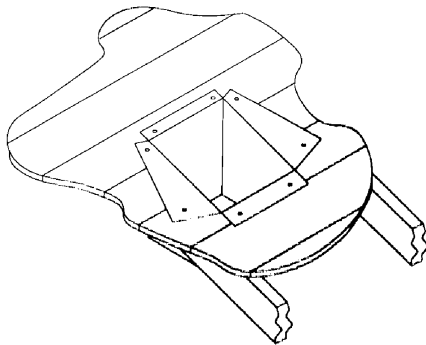
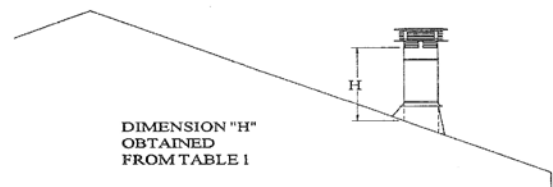

FIG-22



ROOF PITCH	TABLE 1 MINIMUM HEIGHT	
	FEET	METERS
FLAT TO 7/12	1	0.3
OVER 7/12 TO 8/12	1.5	0.46
OVER 8/12 TO 9/12	2	0.61
OVER 9/12 TO 10/12	2.5	0.76
OVER 10/12 TO 11/12	3.25	0.99
OVER 11/12 TO 12/12	4	1.22
OVER 12/12 TO 14/12	5	1.52
OVER 14/12 TO 16/12	6	1.83
OVER 16/12 TO 18/12	7	2.13
OVER 18/12 TO 20/12	7.5	2.29
OVER 20/12 TO 21/12	8	2.44

CATHEDRAL CEILING INSTALLATION

STEP 1. Follow installation steps 1 and 2 under Vertical Termination.

STEP 2. Using the plumb bob, mark the centerline of the venting system on the ceiling and drill a small hole through the ceiling and roof at this point. From the roof, locate the drill hole and mark the outline of the “Cathedral Ceiling Support Box”.

STEP 3. Remove shingles or other roof coverings as necessary to cut the rectangular hole for the “Support Box”. Cut the hole 1/8” larger than the “Support Box” outline.

STEP 4. Lower the “Support Box” through the hole in the roof until the bottom of the “Support Box” protrudes at least 2-inches below the ceiling.(FIG-20), align the “Support Box” both vertically and horizontally with a level. Temporarily tack the “Support Box” in the place through the inside walls and into the roof sheathing.

STEP 5. Using tin snips, cut the “Support Box” from the top corners down to the roofline, and fold the resulting flaps over the roof sheathing.(FIG-21). Before nailing it in to the roof, run a bead of non-hardening mastic around the top edges of the “Support Box”, to make a seal between the box and the roof. Clean out any combustible material from the inside of the “Support Box”.

STEP 6. Complete the cathedral ceiling installation by following the same procedures outlined in Steps 4 through 9 for “Vertical Termination”.

SHERWOOD INDUSTRIES LTD VENTING KITS

Inspect this kit to ensure this kit is complete and there is no damage to any of the components. If damage is present contact your dealer or your courier company. If some components are missing or damaged do not attempt the installation.

Decide on a location for the unit that will meet any or all, local code requirements. Refer to sections in this manual. Deciding Where To Locate Your Stove, and Planning Your Installation.

Set the appliance in the desired location. Check to determine if any wall studs, electrical wiring or plumbing pipes are in the way of the venting system as it passes through the wall. If obstructions are found in the wall it may be required to adjust the location of the appliance.

Set the appliance in the desired location. Temporarily place the 24” section of pipe (without the crimped end) on the unit and install the 90° elbow pointing in the direction that the vent will exit the structure. Project a level line from the center point of the elbow. Using this center point, scribe a 10” hole or square on the wall. Cut the hole out on both the interior and exterior wall surfaces. Install the wall thimble and secure this thimble on both the inner and outer wall surfaces.

With the appliance still in place install the 24” horizontal section on the elbow and let this section of pipe protrude through the exterior wall. Mark this pipe so that it is flush with the exterior surface and cut this section of pipe.

Dismantle the outer pipe sections.

Remove the 4” flue collar from the unit and remove any loose sealant, install the new 4” diameter x 5” high flue collar provided in this kit.

Attach the flexible liner to the vent termination cap by placing a small bead of high temperature silicone on the vent terminal and slide the flex liner onto the vent terminal and secure with 3 sheet metal screws evenly spaced.

Dress the flex liner through the wall thimble and attach the vent terminal to the outside of the house using 4 wood screws provided. (The use of non-hardening mastic should be used around the vent to ensure a watertight seal.)

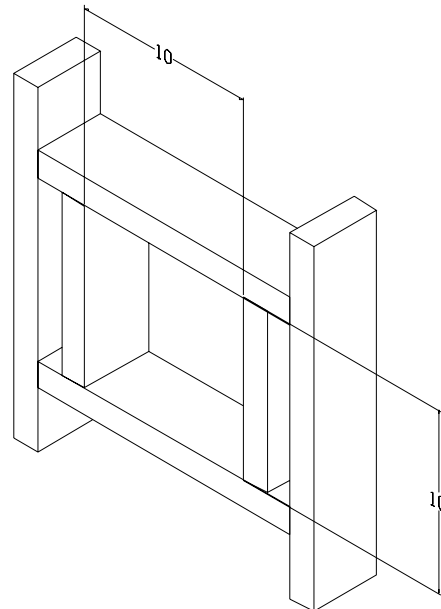

Install 2 spacers around the flex pipe. Slide the horizontal section of pipe over the flexible liner and install through the wall thimble, ensure that this portion of pipe slides onto the vent termination cap. Slide the inside finished collar over the horizontal section of pipe and secure to wall using the screws provided. Slide the 90° elbow over the flex pipe. Stretch the flex liner to a length long enough to ensure the flex liner can be easily connected to the flue outlet of the appliance. Install the remaining spacers over the flexible liner and install the vertical section of pipe. **(DO NOT SLIP THESE SECTIONS OF PIPE TOGETHER, YOU WILL REQUIRE SOME MOVEMENT IN THESE PIPE SECTIONS IN ORDER TO SECURE THE FLEX PIPE TO THE FLUE OUTLET ON THE APPLIANCE.)**

Place a bead of high temperature silicone on the flue pipe and slide flex liner over collar, secure the flex liner with 3 sheet metal screws evenly spaced.

Align all straight sections of pipe, slipping all joints together and installing 3 sheet metal screws evenly spaced.

A small can of touch up paint has been supplied with this kit. Lightly touch up any scratches that might have occurred during the installation process.

Install brass decorative rings around each joint making sure this decorative ring covers the sheet metal screws which secure each section of pipe together and secure to vent pipe in the slotted tab on the backside of the pipe so that the fastener would not be easily seen.

Secure the horizontal section of pipe to the inside finished collar by installing a screw in the tab on the inside finished collar. **(THIS WILL PREVENT THE PIPE FROM BEING DISCONNECTED AT THE VENT TERMINAL.)**

Light the appliance and ensure proper operation.

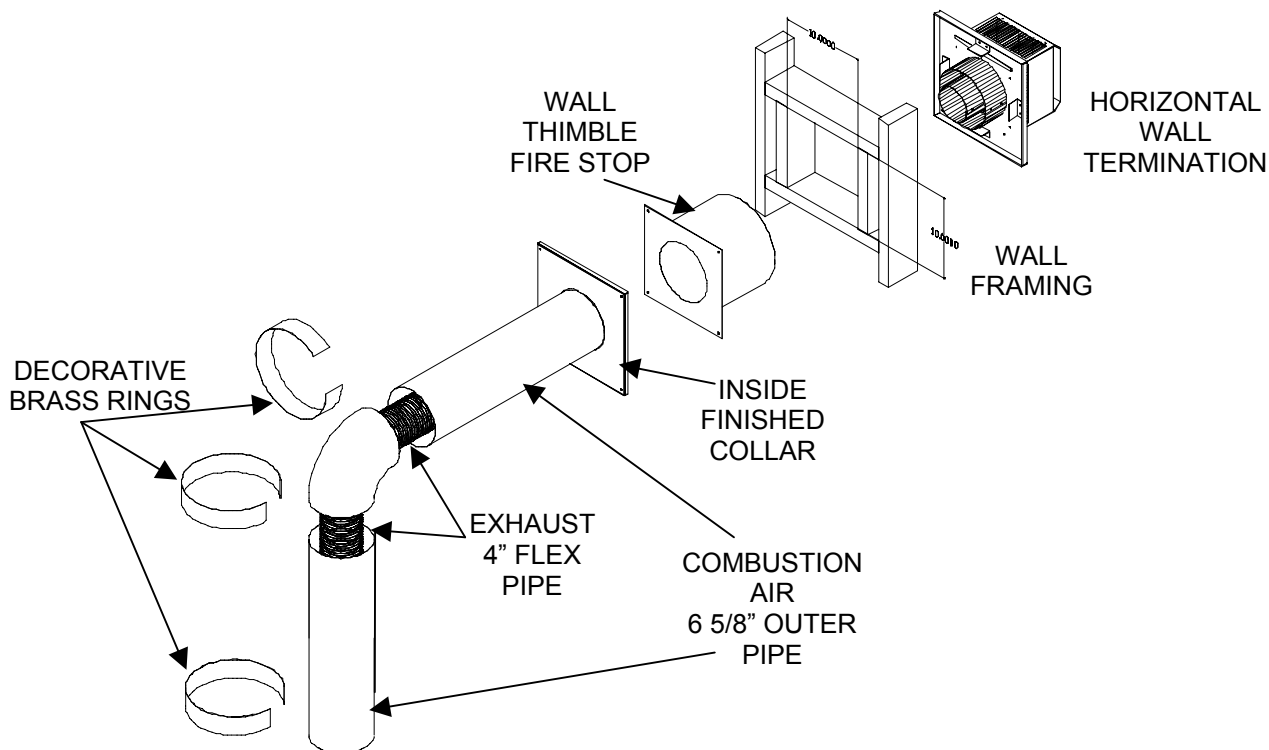
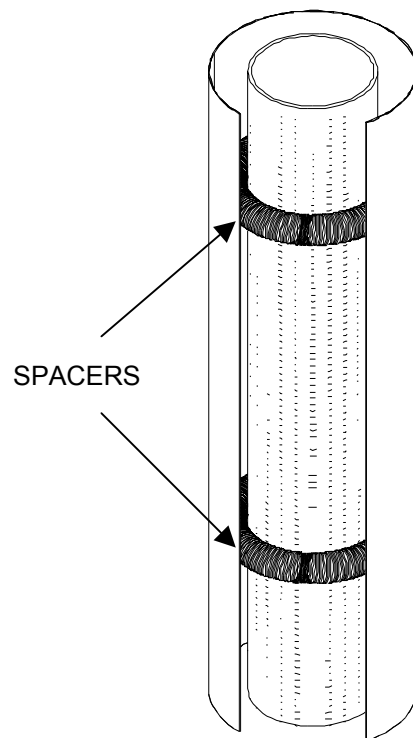

VENTING INTO CLASS "A" CHIMNEYS

This model is also certified and tested to vent into CLASS "A" wood stove chimneys
Place the freestanding direct vent appliance in the desired location.

Using Simpson Dura Vent conversion kit #s 931-932-933, depend on the ID diameter of the CLASS "A" chimney that this appliance is to be vented into.

Place a bead of high temperature silicone or mill pac at each connection to ensure a tight seal.

NOTE: A 4" flex liner must be used in the application.

NOTE: Use Simpson Dura Vent from the top of the appliance until this vent reaches the CLASS "A" chimney. Install the retro adapter to the top section of GS direct vent pipe and install the flex liner to the retro adapter.

Fully liner the CLASS "A" chimney with a minimum 4" flex liner to the top of the CLASS "A" chimney.

Placing a bead of high temperature silicone to the Simpson Cap adapter and securely attach the flex liner to the adapter.

Secure the cap adapter to the CLASS "A" chimney ensuring an air tight seal.

Install the vertical termination cap.

Light the unit and ensure proper operation.

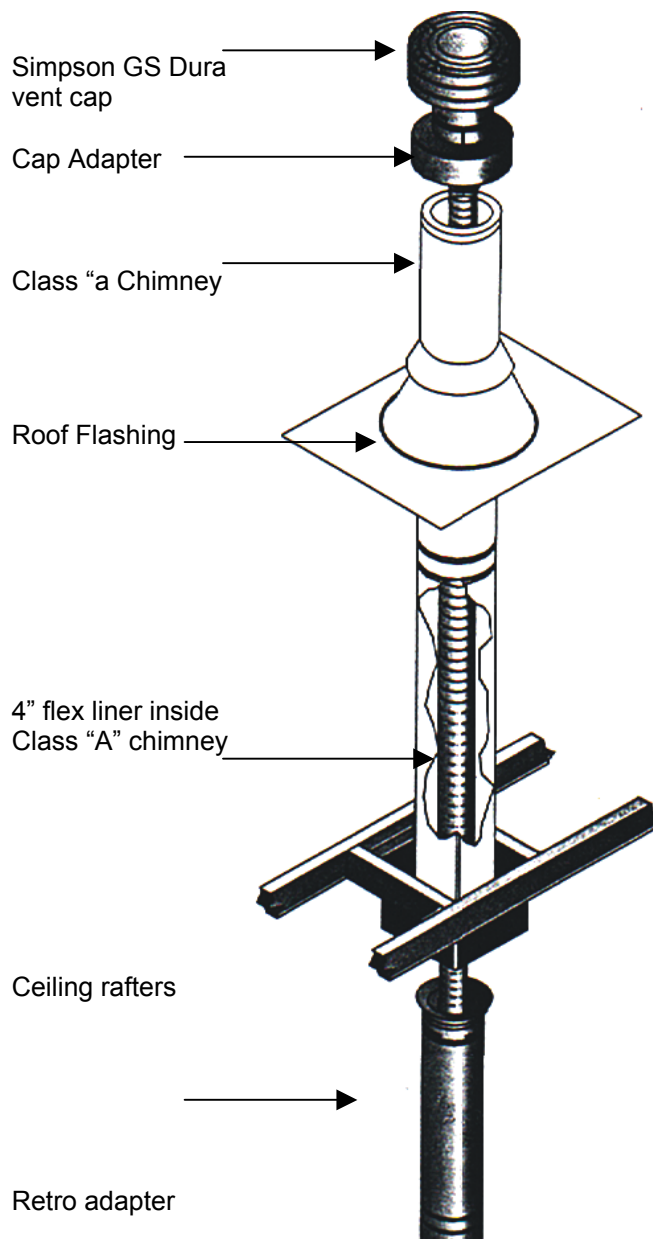

THE USE OF ANY EXISTING CHIMNEY AS AN AIR INTAKE IS NOT COVERED UNDER THE ANSI Z21.88-1999 CSA 2.33-M99 TEST METHODS AND THE RESULTING ITS/WH PRODUCT CERTIFICATION. THE CODE AUTHORITY HAVING JURISDICTION MUST BE CONSULTED PRIOR TO PROCEEDING WITH THIS INSTALLATION METHOD.

CONVERTING TOP VENTED TO REAR VENT

This unit has been shipped as a 30,000 Btu top-vented freestanding unit. This unit can be converted to a rear vented unit for some installation applications.

1. To convert this unit to a rear vented model you must remove the flue pipe adapter and turn to the rear vent position. You must also change the main burner orifice if venting straight out the wall (see page 17)
2. Carefully remove the trivet and the stovetop. Place on a soft surface as not to damage the porcelain finishes.
3. Remove the four screws that hold the flue connection to the unit body. Carefully remove the elbow being sure not to damage the gasket that is glued to the flue collar elbow.
4. Turn the elbow to the desired position and re-fasten with the screws removed from the previous step. (SEE BLOW FOR MORE INFORMATION)

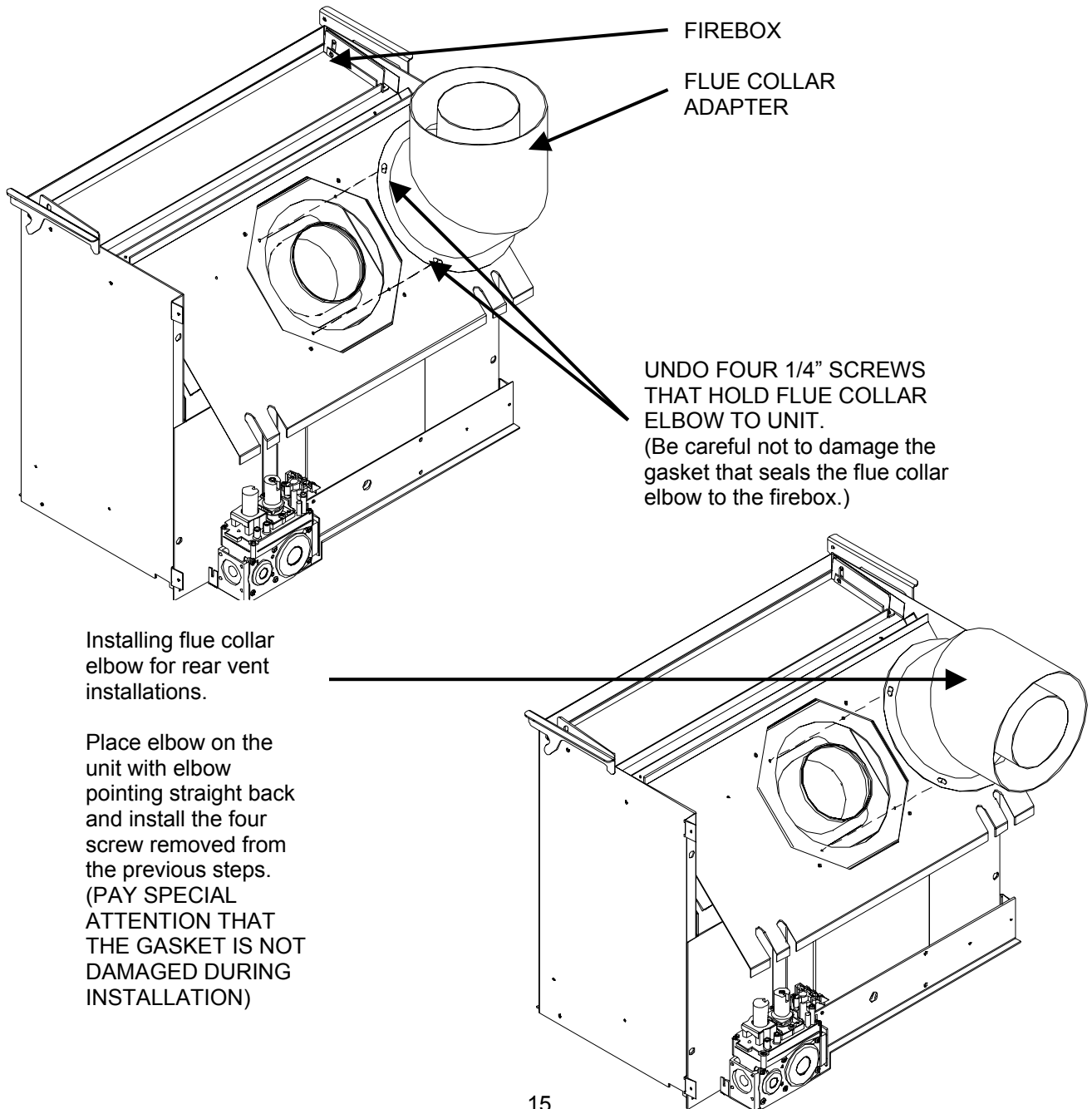

CONVERTING MAIN BURNER ORIFICE FOR REAR VENT INSTALLATION

Carefully lift the units top off, Westport models be careful, that the trivet is a separate piece and may fall out causing damage to porcelain finishes. Place the units top on a soft surface to prevent damage.

1. Lift up on inner door handles and remove door with glass.
2. Carefully remove the log set and ember material.
3. Remove the two screws (located on the outside edge of the burner) that hold the burner to the chassis inside the firebox.
4. Remove the burner from the firebox.
5. Using a 1/2" deep socket remove the main burner orifice from the rear of the unit.
6. If changing to LP (Propane gas) the pilot injector must also be replaced with the proper fuel type injector. Simply pull the pilot head straight up, using a 5/32" Allen key remove the pilot injector and replace the proper fuel type needed.
7. Re-assemble the appliance in the reverse order as above. (Pay special attention when installing the burner that the venturi adjustment rod is properly installed into the venturi adjustment piece welded to the burner venturi tube.)

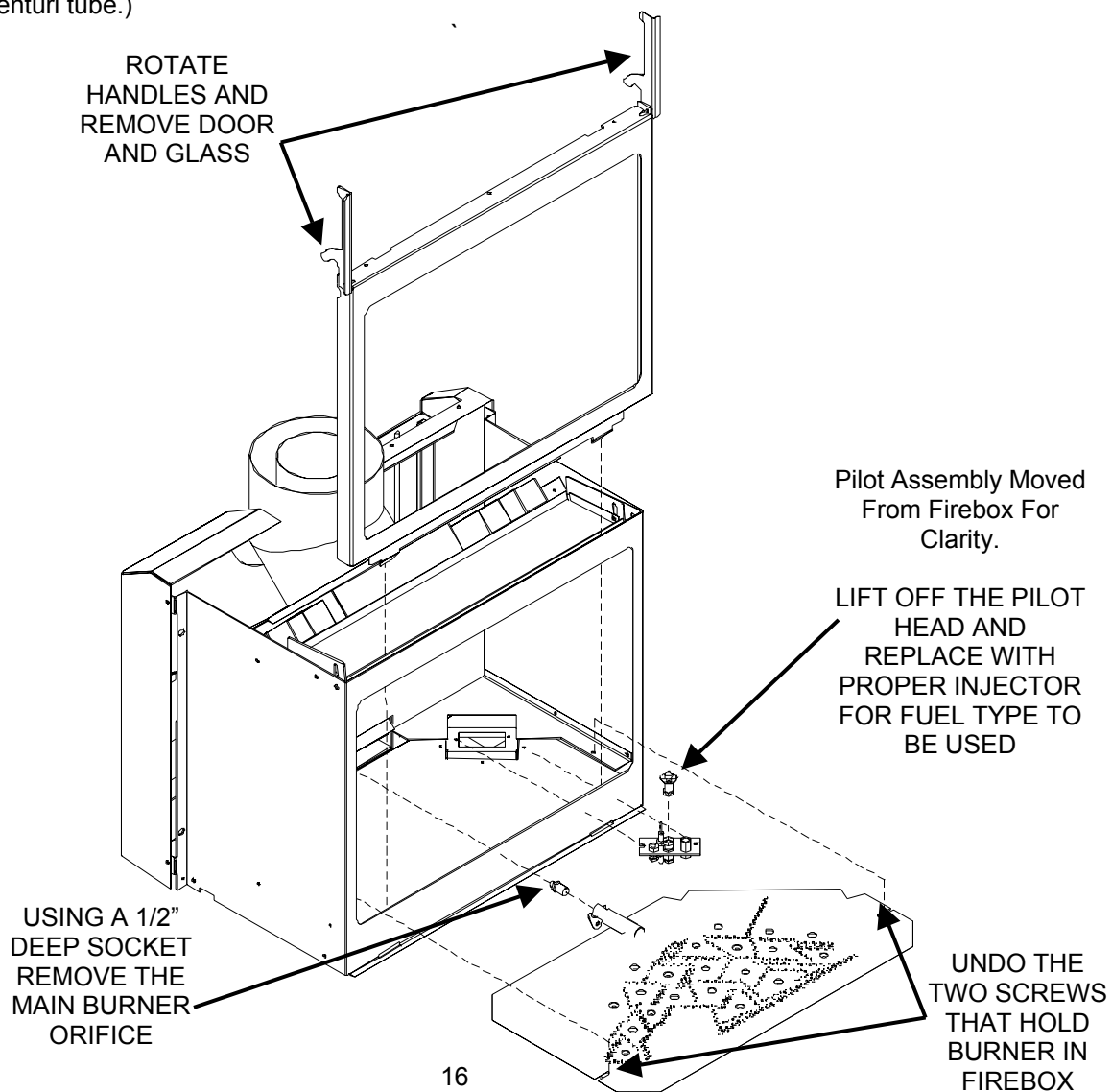

INSTALLATION 20,000 BTUs

REAR VENTED 20,000 BTUs ONLY;

This model is designed for flat wall installation only were a vent is to be concealed. If more distance is required for a longer chimney or vent, Use TOP VENTED model for this type of installation.

NOTE; Vent pipe must be not be longer than 10 inches (25.4 CM) maximum.

VENT RESTRICTOR. The vent restrictor should be placed in the open position. Do not alter this position.
(See PAGE 16 for restrictor settings)

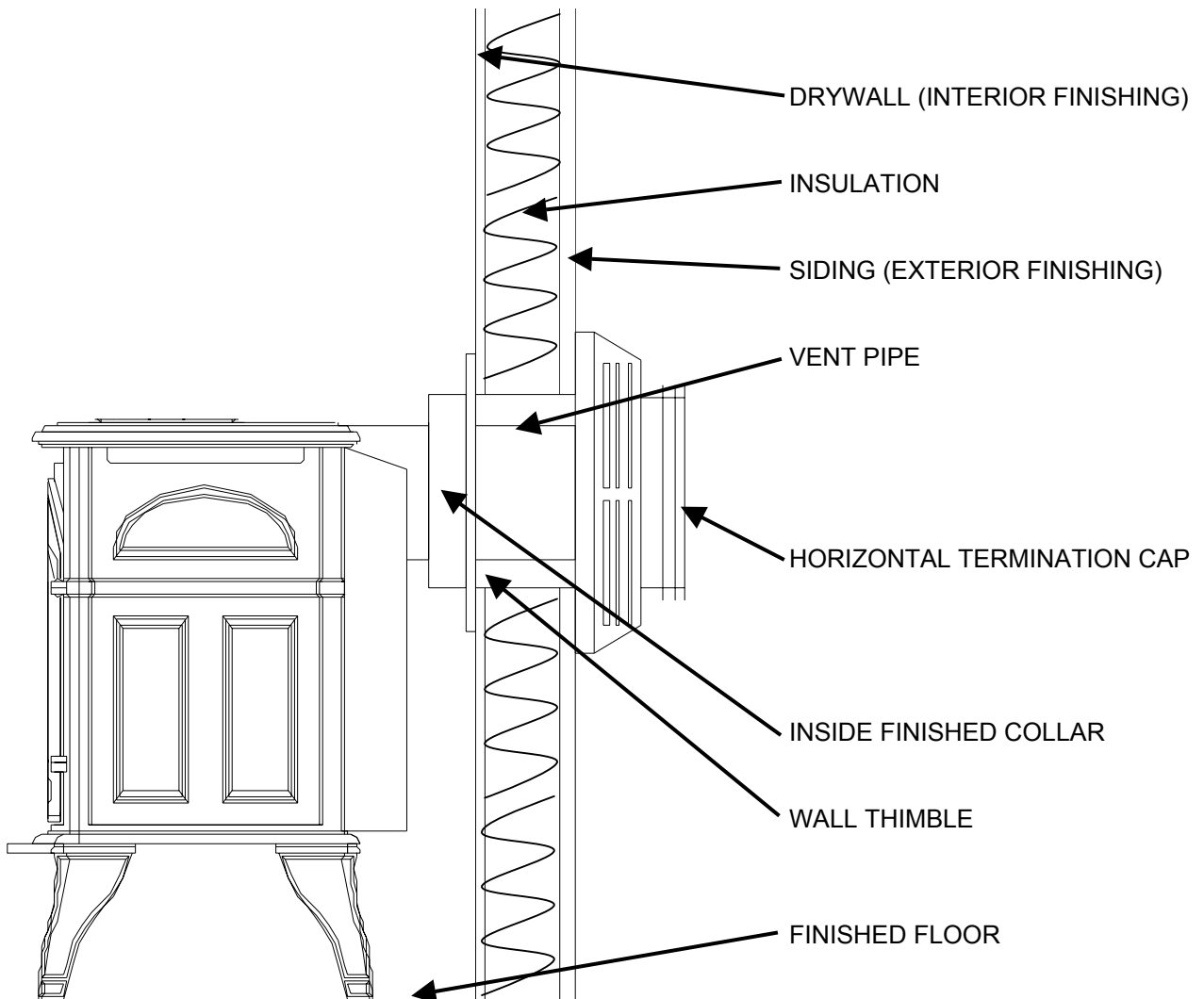

BASIC VENTING 30,000 BTUs

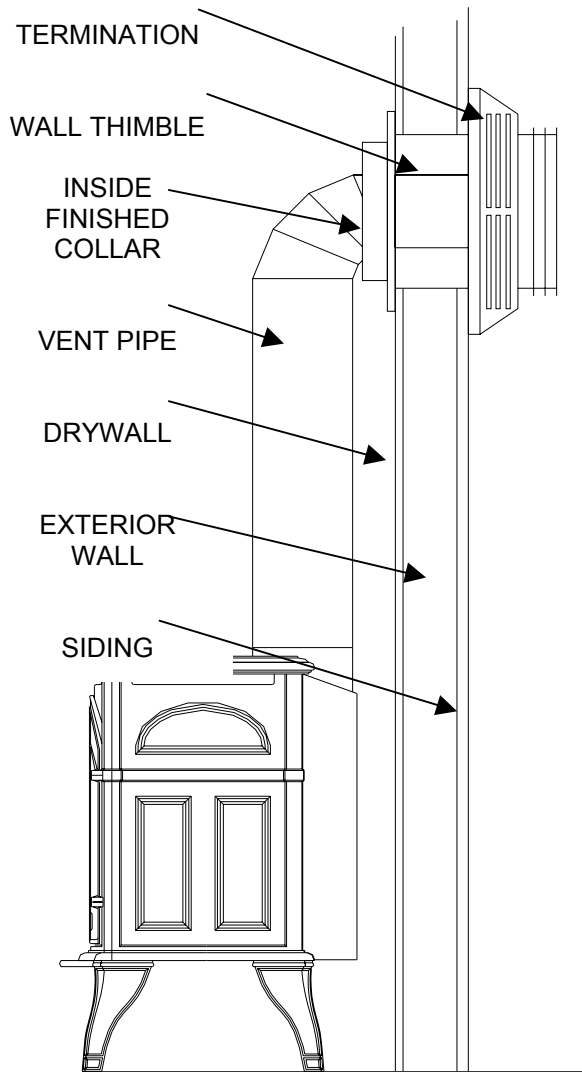

REAR VENTING THIS UNIT.

Place the unit into place.
 Attach a small section of pipe on the unit and mark exterior wall where vent would pass through the wall.
 Cut a 10" inch minimum hole in the wall to maintain clearances to combustibles.
 Install a wall thimble.
 Install interior finished collar.
 Install the vent section through the wall.

THIS UNIT MUST BE VENTED WITH A 36" SNORKEL KIT IF UNIT IS RATED FOR 30,000 BTUs.

Seal the vent terminal to the structure using a non-hardening mastic.

MOST COMMON INSTALLATION

Set the unit in place.
 Install a minimum 24" (2 foot) vertical chimney.
 Install a 90° degree elbow, and mark the exterior wall where the vent would pass through.
 Cut a 10" inch minimum hole in the wall to maintain clearances to combustibles around vent pipe.
 Install wall thimble.
 Install interior finished collar
 Install the vent section through the wall and then install the vent termination.
 Seal around the termination using a non-hardening mastic.

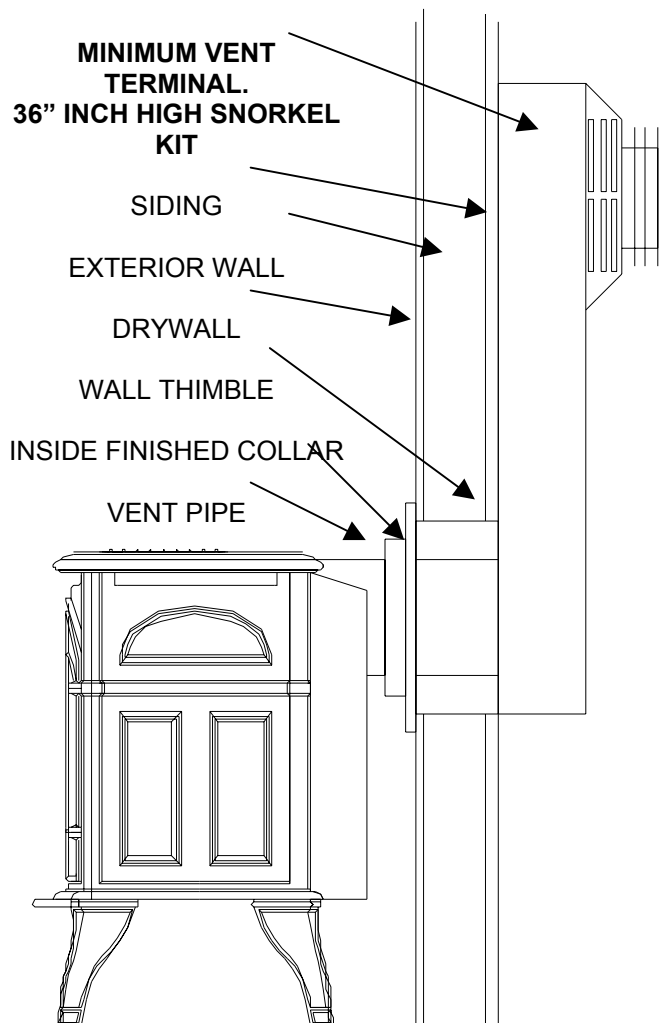

VENTING CONTINUED 30,000 BTUs

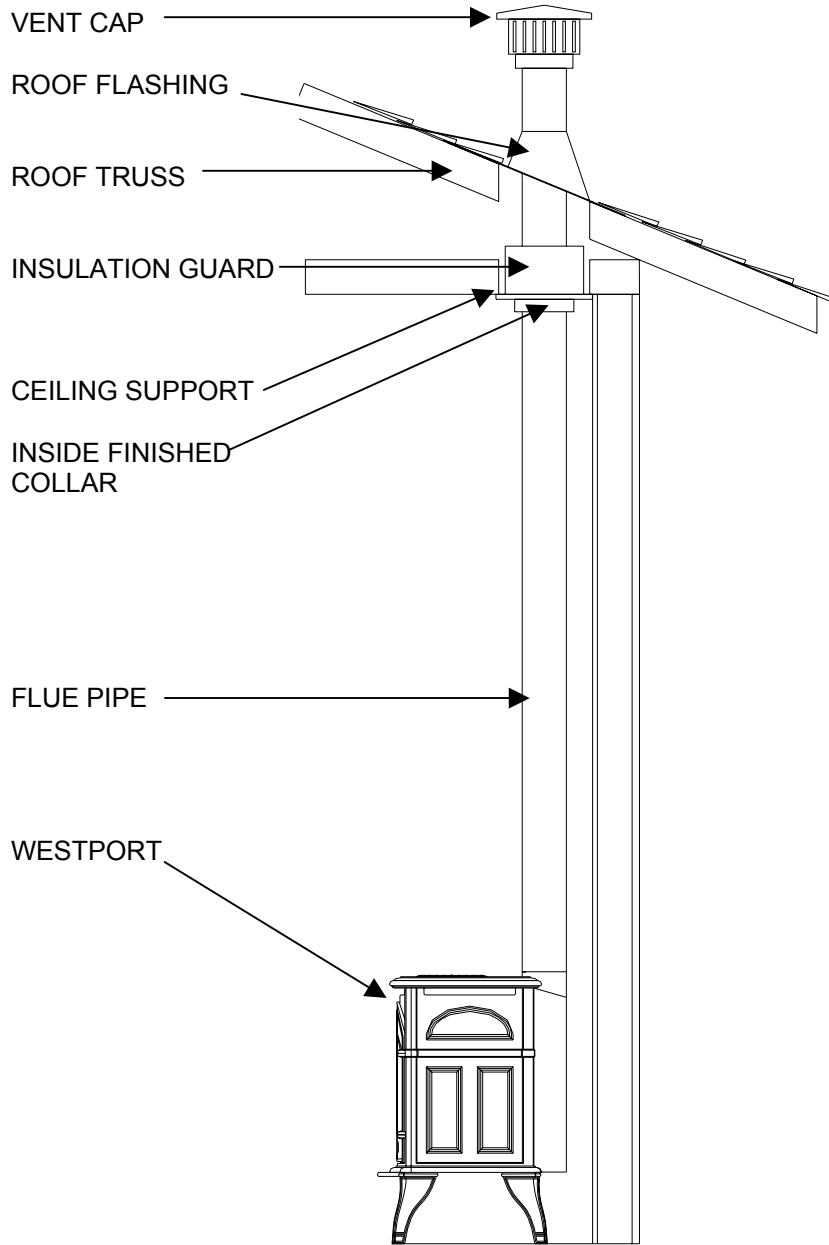

INSTALL VERTICAL VENTING

Place the unit in place.

Drop a plumb bob from the ceiling to the center point of the flue outlet.

Cut a 10" inch hole in the ceiling and the roof.

Install the ceiling support and insulation guard.

Install the roof flashing. Ensure that the roof flashing is installed under the roofing material so that a watertight seal is created.

Install the flue pipe from the top of the unit through the roof.

Ensure that all flue pipe and unit maintain required clearances to combustibles.

VENT RESTRICTION

The **ENVIRO WESTPORT / BEDFORD** has been designed with a built in Restrictor plate.

The restrictor is designed to enhance flame appearance when installing this unit with vertical chimneys as well as installations with longer horizontal vent applications. Use the following chart to adjust the vent restrictor plate for the proper setting.

VENT RESTRICTOR

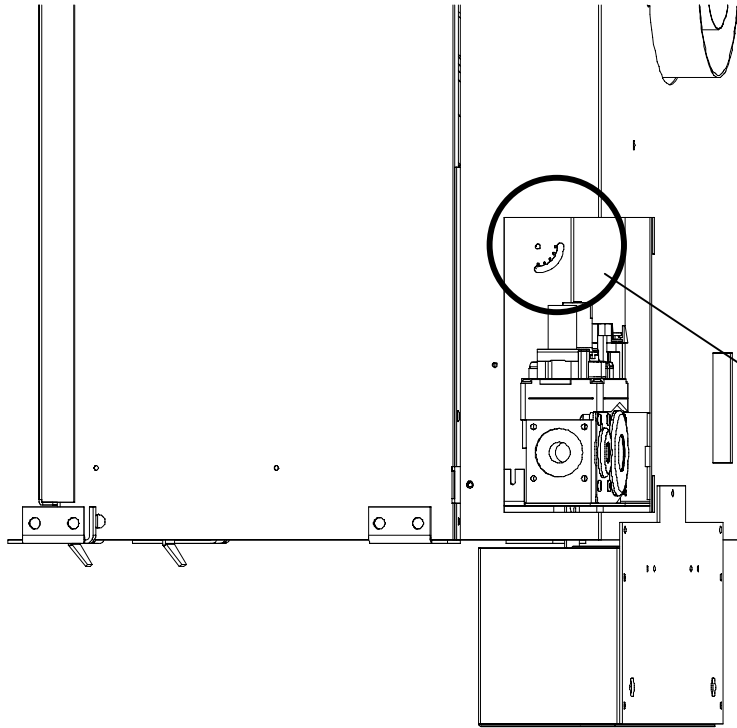

To access, remove the valve cover plate from the right rear corner of the unit by undoing the two fastening screws.

Loosen the 1/4 hex head bolt and adjust to the correct setting.

Slide the hex head bolt to the next setting and re-tighten the bolt to secure in place.

View showing fully closed restrictor plate.

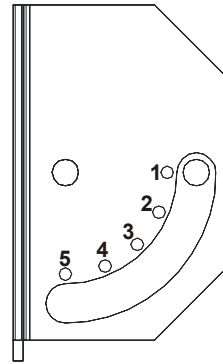
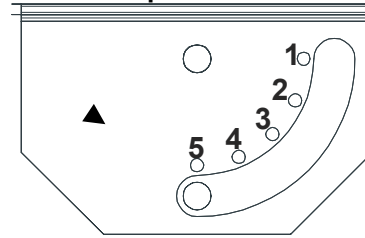

View showing fully open restrictor plate.

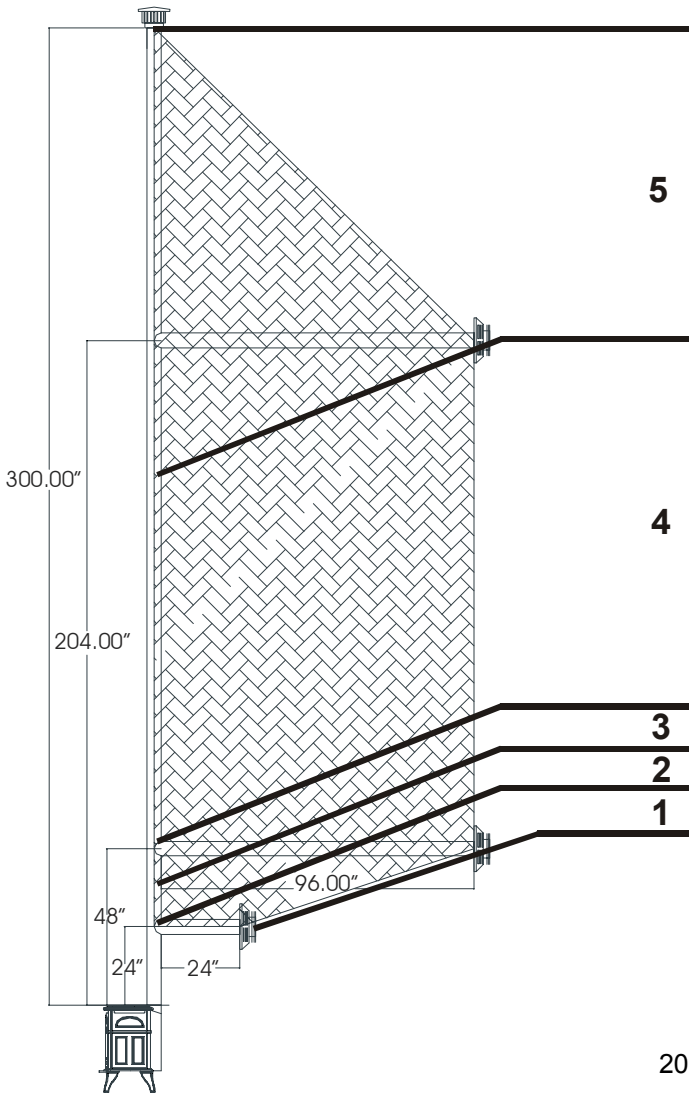

The maximum length of flue that can be attached to the **ENVIRO WESTPORT** would be 300.00", 25' (762 cm) with a maximum horizontal vent length of 96", 8' (244 cm)

RESTRICTOR SETTINGS

4

Follow this chart provided to determine where the vent restrictor should be set.

The numbers in this chart represent the actual vent restrictor settings. Although the numbers do not appear on the unit use this as a guide to follow.

3

Undo the set-screw and adjust the restrictor to the correct setting.

2

1

Ensure that the set-screw is re-tightened and the unit is checked for proper operation.

Wait for unit to warm up to operating temperature to ensure proper and clean burning unit.

ELECTRICAL REQUIREMENTS

The **ENVIRO WESTPORT/ BEDFORD** will operate without electrical power. This model has a Milli volt gas control which uses the pilot flame to generate enough electricity to operate the main burners. The appliance when equipped with an optional blower must be electrically connected and grounded in accordance with local codes or in the absence of local codes, with the current CSA C22.1 CANADIAN ELECTRICAL CODE Part 1, SAFETY STANDARDS FOR ELECTRICAL INSTALLATIONS, OR THE NATIONAL ELECTRICAL CODE ANSI / NFPA 70 in the U.S.

WARNING: Electrical grounding instructions. This appliance is equipped with a three-prong (grounding) plug for your protection against shock hazard, and should be plugged directly into a properly grounded three-prong outlet. DO NOT cut or remove the grounding prong from this plug.

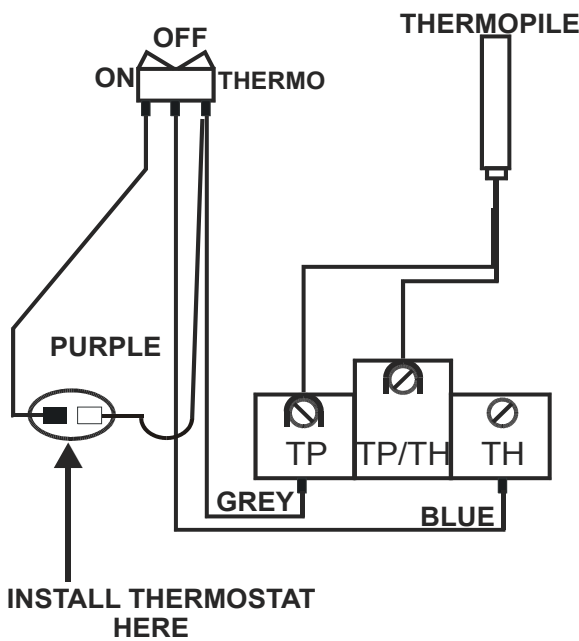

CAUTION: Label all wires prior to disconnection when servicing controls. Wiring errors can cause improper and dangerous operation. Verify proper operation after servicing

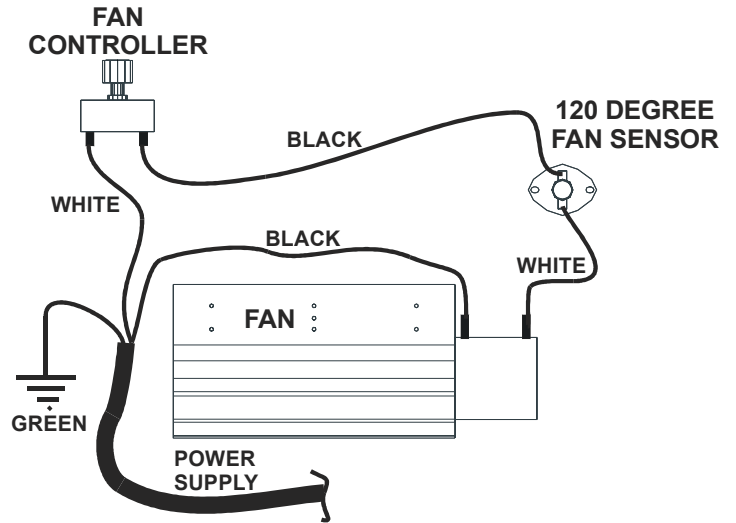

INSTALLING OPTIONAL BLOWER

Remove the pre assembled blower from the packaging. Inspect the blower for damage. If damage is noticed call your dealer, distributor or courier company and have components replaced.

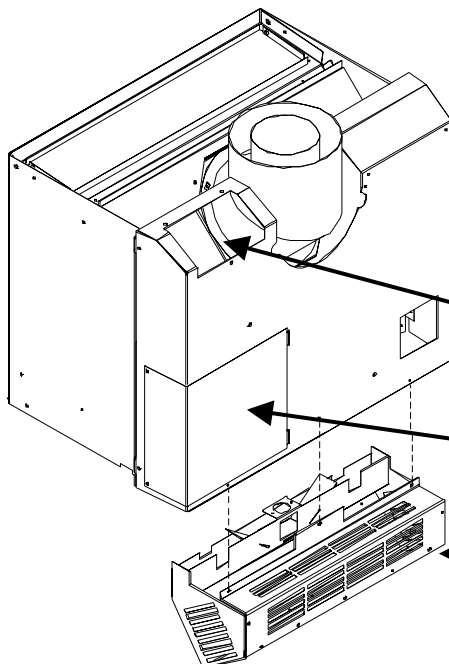

TO INSTALL:

Place the fan assembly behind the unit and secure with the three screws provided. (As shown beside)

Open the gas valve cover. Carefully cut the decal portion on the control panel and install the fan control switch in this location

Plug the fan assembly into the wall outlet and turn the unit on to ensure fan operation.

CONTROL PANEL.
(Fan Control location)

VALVE COVER

FAN ASSEMBLY

GAS LINE CONNECTION and TESTING

WARNING: Only persons licensed to work with gas piping, may make the necessary gas connections to this appliance.

GAS LINE CONNECTION

- This stove is equipped with a certified flexible pipe located on the right side of the unit terminating in a 3/8" male NPT fitting. Consult your local authorities codes or the CAN/CGA B 149 (1 or 2) installation code in Canada, or in the USA gas installations follow either local codes or the current edition of the National Fuel Gas Code ANSI Z223.1.
- The efficiency rating of this appliance is a product thermal efficiency rating determined under continuous operating conditions and was determined independently of any installed system.

The appliance and its shutoff valves must be disconnected from the gas supply piping system during any pressure testing where the pressure exceeds 1/2 PSIG (3.45 kpa) or damage will occur to the valve.

The appliance must be isolated from the gas supply piping system by closing its individual manual shutoff valve during any pressure testing of the gas supply piping system at test pressures equal to or less than 1/2 psig (3.45 kPa).

Always check for gas leaks with a soap and water solution after completing the required pressure test.

TO TEST VALVE PRESSURES

The pressure taps are located on the left side of the valve

- Turn set screw 1 turn counter clockwise to loosen,.
- Place 5/16" (8 mm) I.D. hose over pressure tap system.
- Check pressures using a manometer.
- When finished, release pressure, remove hose & tighten set screw.

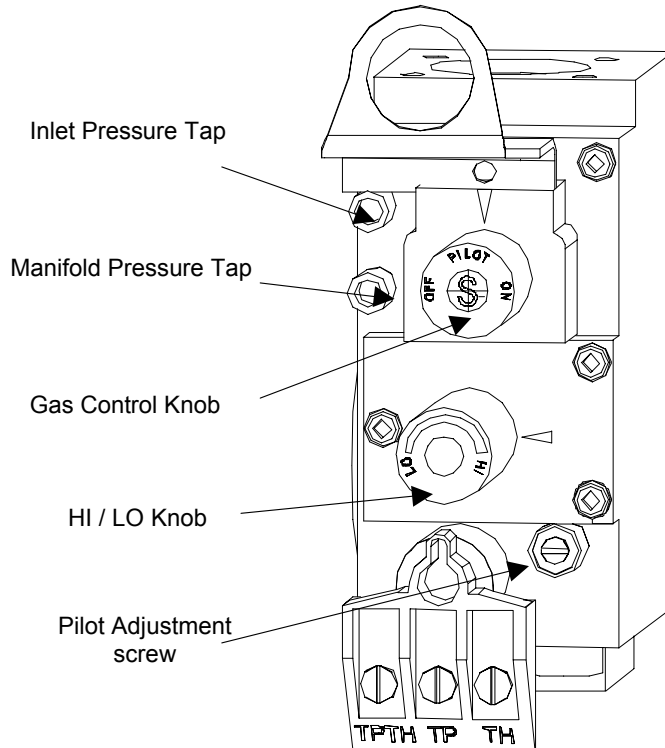

	NATURAL GAS	PROPANE GAS
MAIN BURNER	TOP VENT # 39 DMS REAR VENT # 46 DMS	TOP VENT # 53 DMS REAR VENT # 55 DMS
Manifold Press:	3.8"wc / 0.95 kpa	11.0"wc / 2.74 kpa
Min. Manifold Press:	1.1"wc / 0.27 kpa	2.7"wc / 0.67 kpa
Max. Supply Press:	7.0"wc / 1.74 kpa	13.0"wc / 3.28 kpa
Min. Supply Press:	5"wc / 1.24 kpa	12"wc / 2.98 kpa
Max. BTUH Input:	TOP VENT 30,000 / 8.8 Kw REAR VENT 20,000 / 5.86 Kw	TOP VENT 26,500 / 7.76 Kw REAR VENT 20,000 / 5.86 Kw
Min. BTUH Input:	TOP VENT 17,000 / 4.98 Kw REAR VENT 12,000 / 3.51 Kw	TOP VENT 14,000 / 4.10 Kw REAR VENT 11,000 / 3.22 Kw

NEVER USE AN OPEN FLAME FOR LEAK TESTING

INSTALLATION OF LOG SET, EMBERS

INSTALLING THE GLOWING EMBERS and LOG SET

A bag of ceramic fiber embers and rock wool embers are provided and should be placed on the burner. **DO NOT** pack this ember material as this could create an unsafe condition.

CAUTION: Use only the type of ember material supplied with this appliance. Due to the irregular size of the ember material there may be more than required. The use of other foreign materials on the burners may create dangerous conditions.

If over time, through cleaning and servicing, these embers require replacement, contact your nearest ENVIROGAS dealer for replacement embers.

1. Carefully remove log from unit. Check to ensure there is no damage. It is very important to install this log in its proper position to insure safe, optimum operating conditions.
2. Place the log set into the firebox. Locate each log by seating it down onto the burner tray supports (pins). Follow the plan view provided for proper log placement.
3. Gently remove the ember material from the plastic bag. Spread a layer loosely across the burner tray. Do not allow any embers to rest against any pilot assembly. (see diagram provided for proper ember placement.)
4. Do not pack down, leave embers loose

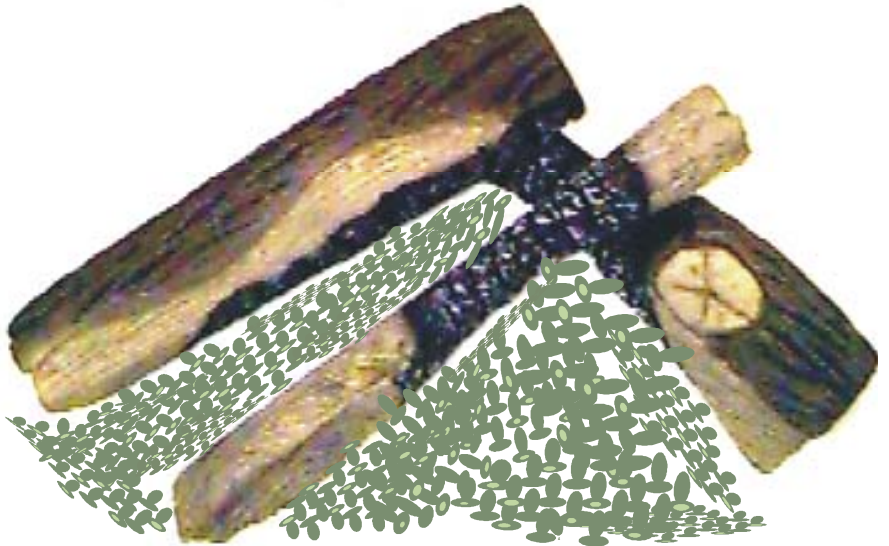

5. Upon the first light up, watch for ignition to **ALL** burner ports. If a long delay is noted:
First, wait for the appliance to cool down
 - Open the front door of the appliance.
 - Check to carefully reposition the embers making sure that burner ports are not plugged solid or blocked

CAUTION: NEVER OPERATE THIS APPLIANCE WITH THE DOOR REMOVED

OPERATING INSTRUCTIONS

FOR YOUR SAFETY READ BEFORE OPERATING

WARNING: IF YOU DO NOT FOLLOW THESE INSTRUCTIONS EXACTLY, A FIRE OR EXPLOSION MAY RESULT CAUSING PROPERTY DAMAGE, PERSONAL INJURY OR LOSS OF LIFE.

- A) This appliance is equipped with a pilot that must be lit by hand by following these instructions exactly.
- B) BEFORE LIGHTING smell all around the appliance area for gas, and next to the floor because some gas is heavier than air and will settle on the floor.

WHAT TO DO IF YOU SMELL GAS:

- Do not try to light any appliance.
 - Do not touch any electrical switch; do not use any phone in your building.
 - Immediately call your gas supplier from a neighbor's phone. Follow the gas supplier instructions.
 - If you cannot reach your gas supplier, call the fire department.
- C) Use only your hand to push in or turn the gas control knob. Never use tools. If the knob will not push in or turn by hand, do not attempt to repair it. Call a qualified service technician. Force or attempted repair may result in a fire or explosion.
- D) Do not use this appliance if any part has been under water. Immediately call a qualified service technician to inspect the appliance and to replace any part of the control system and any gas control which has been under water

LIGHTING INSTRUCTIONS

1. STOP! Read the safety information above.
 2. Turn off all electrical power to the appliance.
 3. Turn the gas control knob clockwise to the "off" position.
- If the knob does not pop up when released, stop and immediately call your service technician or gas supplier.
 - If the pilot will not stay lit after several tries, turn the gas control knob to "OFF" and call your service technician or gas supplier.

4. Open door. **Wait five (5) minutes to clear out any gas.** Close door. If you smell gas including near the floor, **STOP!** Follow "B" in the above safety information. If you don't smell gas go to next step.

5. Find the pilot located to the back right hand corner, behind the right log.

6. Turn gas control knob counter-clockwise to "PILOT".

7. Push the gas control knob in fully and hold. A BATTERY operated electronic igniter will light the pilot. Keep knob depressed for about 30 seconds after pilot is lit. Release knob. If pilot goes out, repeat steps 4 through 6.

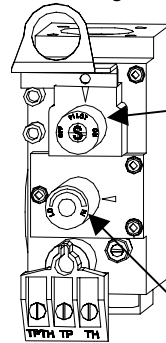

8. Turn gas control knob counter-clockwise to the "ON" position.

Flip burner switch to "ON"

Turn "HI / LO" knob to the desired setting.

Turn on all electrical power to the unit

WARNING: The gas valve has an lockout device which will not allow the pilot burner to be re-lit until the thermocouple has cooled.

NOTE: Check to be sure the pilot flame engulfs the thermocouple and that the burners light completely.

TO TURN OFF GAS TO APPLIANCE

1. Flip burner switch to off, to turn off burners only.
2. Turn the gas control knob clockwise to "OFF" DO NOT FORCE
3. Turn off all electrical power to the appliance if service is to be performed

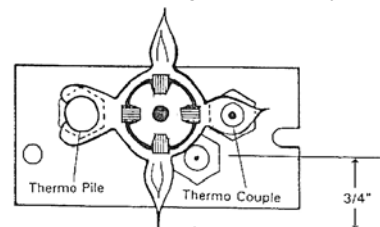

ROUTINE MAINTENANCE and SERVICE

Periodically check to ensure that your system is clean.

Periodically check the pilot and burner. Check to see that all the burner ports are clean and clear. Check the pilot head for blockage. Check to ensure the pilot flame is blue with no or very small yellow tips.

OPENING THE DOOR

Turn unit off and wait until the appliance has cooled down.

Remove the unit top from the unit by lifting straight up.

Lift the two door handles located on either side of the door and lift the glass door assembly straight up and out.

Carefully open the two doors and remove if necessary.

Ensure the door is properly fastened after cleaning before attempting to re-light the appliance.

CLEANING THE GLASS

Do not clean glass when hot

It will be necessary to clean the ceramic glass periodically. During a cold start up, condensation will sometimes form on the glass, this is a normal condition with all gas fireplaces and stoves. However, this condensation can allow dust and lint to cling to the glass surface. Initial paint curing of the appliance can leave behind a slight film on the glass. This is a temporary problem. It is therefore recommended that the glass be cleaned initially after about the first two weeks of use.

Depending upon the amount of use, cleaning should be required no more than two or three times per season.

To clean the door, use a **mild glass cleaner** and a **soft cloth**. **Abrasive cleaners will damage the glass and gold surfaces.**

TO REPLACE DOOR GLASS

The glass in this appliance is ceramic. If the glass is damaged or broken a factory replacement must be fitted.

To Replace:

- Open door, remove the glass carefully.
- Install the new piece of glass with the large bulb in the gasket tape against the unit. Place the joint in the tape in a bottom corner. Close door

Glass must be purchased from an ENVIROGAS dealer.

No substitute materials are allowed.

CLEANING THE INSIDE OF THE FIREBOX

Remove the log carefully from the firebox. Gently remove the embers and place on a piece of paper towel. Until ready to replace.

Vacuum the bottom of the firebox thoroughly. Carefully clean off any dust on the logs and remove any lint from the main burner and pilot burner.

After carefully replacing the log and embers in their correct positions, and the door has been resealed, re-light the pilot, following the instructions on the attached label.

CLEARANCES MUST BE SUFFICIENT TO ALLOW ACCESS FOR MAINTENANCE AND SERVICE

WARNING: Failure to position the parts in accordance with these diagrams or failure to use only parts specifically approved with this appliance may result in property damage or personal injury.

ELECTRONIC IGNITION (BATTERY REPLACEMENT)

If the unit does not spark when lighting, the battery in the electronic ignition could need replacing.

Located on the left hand rear corner of the unit is a small rectangular hole. Located here is the electronic ignition module.

Remove the battery cover and replace battery using a "A A" battery.

Reinstall the battery cover and check for spark by depressing the pilot knob located on the control panel

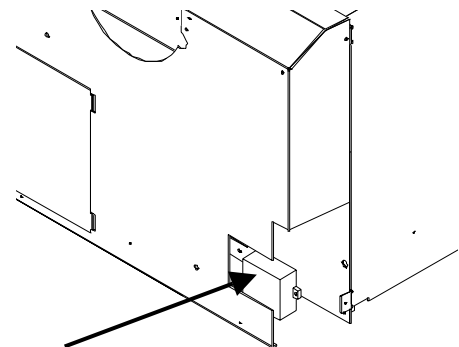
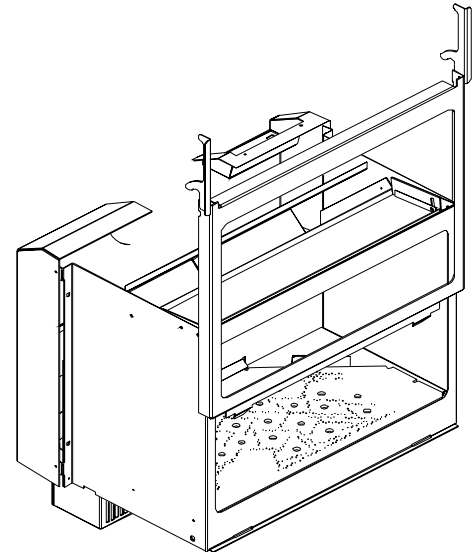

ELECTRONIC
IGNITION
MODULE

FUEL CONVERSION

ENVIROGAS WESTPORT/ BEDFORD Top Vent / Rear Vent

“Warning” This conversion kit shall be installed by a qualified service technician in accordance with the manufacturer’s instructions and all applicable codes and requirements of the authority having jurisdiction. If the information in these instructions is not followed exactly, a fire, explosion or CO poisoning may result. The qualified service agency is responsible for the proper installation of this kit. The installation is not proper or complete until the operation of the converted appliance is checked as specified in the owner’s conversion kit.

Please read and follow these instructions. Also please read the instruction guidelines provided by S.I.T on how to remove and install the HI-LOW regulator.

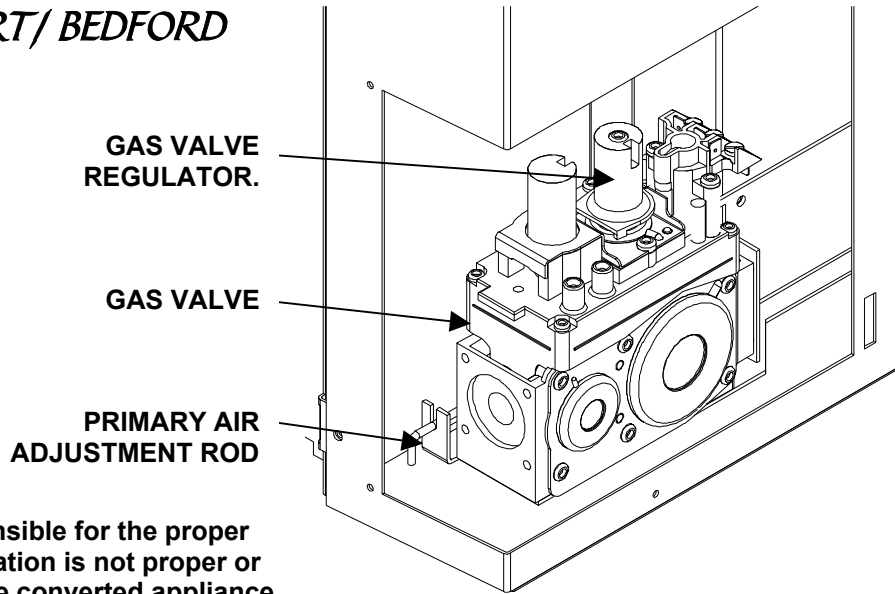

- STEP 1. Carefully inspect all parts supplied with this conversion kit.
- STEP 2. Shut the gas off and disconnect the main gas line from the unit.
- STEP 3. Open the door by lifting the cast iron top off of the unit. Pull the two handles straight up to unlatch the door. Using the two latches lift the door assembly straight up and out of the unit. Swing the front doors open or remove for access the inside of the firebox.
- STEP 4. Change the regulator on the top of the gas valve. (Follow the instructions provided by S.I.T)
- STEP 5. To change the pilot orifice, simply pull the pilot hood straight up to access the pilot injector. Using a 5/32" Allen key remove the pilot injector.
- STEP 6. Install the new pilot injector supplied with this conversion kit, simply screw the new injector inside the pilot hood and reinstall pilot hood by placing hood on the assembly lining up the key way and snap into place.
- STEP 7. Remove the main burner orifice with a 1/2" deep socket.
- STEP 8. Install the new orifice supplied. Be sure to put a bead of pipe thread sealant or approved Teflon tape on the orifice before installing into the burner assembly.
- STEP 9. Reinstall the burner tray, log set and door.(ENSURE THAT THE VENTURI ADJUSTMENT ROD IS CONNECTED TO THE VENTURI TUBE FOR ADJUSTMENT).
- STEP 10. Reconnect the gas line to the unit. Do a leak check using soap and water solution or a approved method on the gas supply line.
- STEP 11. Re-light the appliance to insure proper operation and proper flame appearance. Be sure to adjust the venturi setting to achieve an efficient flame in the fireplace.
- STEP 12. MAKE SURE that the sticker provided by S.I.T is installed to signify that this valve has been converted to a different type of fuel. Also make sure that the rating plate has a conversion label to show that this unit has been converted to a different fuel type.

A VISUAL CHECK OF THE REGULATOR KNOB IS NECESSARY TO DETERMINE WHETHER OR NOT THE REGULATOR IS THE CORRECT PART. A 50% TURN DOWN REGULATOR WILL HAVE ONLY ONE CORNER ON THE KNOB.

- 1 50% turn down HI-LOW Regulator w 3 T-20 Torx screws
- 1 pilot injector
- 1 Main orifice
- Conversion instructions.
- Labels to show conversion.

	NATURAL GAS	PROPANE
Pilot Orifice.	.62 mm	.40 mm
Burner Orifice.	# 39 dms	# 53 dms
Venturi Settings	1/16" min	3/16" min

TROUBLE SHOOTING

Problem	Possible Cause	Solution
Spark will not arc to the pilot after repeated pressing of spark ignitor	Low battery or bad electronic module.	Replace the electronic module or Replace the battery in module.
	Broken spark electrode	-Check for broken ceramic insulation replace, electrode if broken
	Misalign spark electrode	-If spark is not arcing from the electrode to pilot-adjust by loosening screws on pilot base. Adjust away from burner and re-tighten
Pilot will not remain lit	Problem with thermocouple circuit	-Check for proper connection of thermocouple to rear of valve. If loose, tighten lightly -Check pilot for full flame impingement around thermocouple. If the pilot is too small - Check the gas pressure, adjust pilot rate screw, check the pilot head for blockage. -Check thermocouple voltage at rear of valve-must be greater than 7 mV. If low, replace thermocouple.
	Air in gas line - (Pilot flame dies while knob is depressed.)	-Bleed line. -Check gas line pressure. -Contact dealer.
Burners will not remain lit	Problem with thermopile circuit	-Check gas line pressure. -Check for flame impingement on thermopile, if low see "Pilot will not stay lit" -Check thermopile for a Minimum of 200 mV when burner switched on. -Check wiring to thermostat for breaks.
Flame lifting	- Leak in vent pipe - Improper vent configuration - Terminal may be recirculating flue gases - Improperly set vent restrictor plate.	-check for leaks in vent connections -check vent configuration with manual -check to see if terminal is on correctly -May need to install high wind termination cap -contact dealer. -See venting section for proper restrictor setting.
Glass fogs up	Normal conditions - after the appliance warms up glass will clear ** Due to additives in gas, glass may get hazy during normal use** Clean when needed.	
Blue flames	Normal during start - flame will yellow as the appliance heats up.	
Flames are burning "dirty" or Sooting	Flame impingement	-check log position -increase primary air by opening venturi shutters see also "Burners will not stay lit" Check vent restrictor for proper setting.

WARRANTY

Sherwood Industries Ltd. offers a Limited Lifetime Warranty on this gas product. This limited lifetime warranty covers the appliance for a period of seven years from the date of installation. This warranty applies only to the original owner in the original location

Covered under the lifetime warranty are, Surround Panels and Chassis and Heat Exchanger. These steel components are covered against manufacturer's defects for 7 years and labour for the first year. (A) The following exclusions apply:- over-firing due to incorrect setup or tampering, damage caused by incorrect installation, usage or abuse. The unit must be properly installed by a qualified technician or installer, and must meet all local and national gas and building code requirements.

We also cover against manufacture defects under our Limited Lifetime warranty. The following components,

Gold Plating, Log Set, Burners and Glass (A) The following exclusions apply: Porcelain finishes- Damage caused by chipping, scratching, marring, chemicals, fingerprints, abrasive cleaners or discoloration with age. Glass- use of harsh or abrasive cleaners, striking the glass or surface contaminates. Log set- Damage caused by incorrect handling or misuse. Burners- damage caused by improper or continuous operation under incorrect conditions.

Sherwood Industries Ltd. offers a 2-year warranty on all the Electrical Components and Gas Components against manufacturing defects. Paint is covered against flaking. This offer includes parts and labor for 1 year and for parts only thereafter.

Your dealer shall make all claims under this warranty in writing.

WHEN FILING A WARRANTY CLAIM PLEASE COMPLETE THE FOLLOWING INFORMATION ON AN OFFICIAL WARRANTY CLAIM FORM:

TO THE DEALER

Name, address and telephone number of purchaser and date of purchase.

Date of installation. Name of installer and dealer. Serial number of the appliance. Nature of complaint, defects or malfunction, description and part # of any parts replaced.

TO THE DISTRIBUTOR

Sign and verify that work and information are correct.

This warranty covers defects in materials and workmanship only if the product has been installed according to the manual's instructions. If the product is damaged or broken as a result of misuse or mishandling the warranty does not apply. The warranty does not cover removal and re-installation costs.

Sherwood Industries Ltd. reserves the right to repair or to replace the defective product. The shipping costs are to be paid by the consumer. All warranties by the manufacture are set forth herein and no claim shall be made against the manufacturer on any oral warranty or representation.

Sherwood Industries Ltd. and its employees or representatives will not assume any damages, either directly or indirectly caused by improper usage, operation, installation, servicing or maintenance of this appliance.

Sherwood Industries Ltd. reserves the right to make changes without notice. Please complete and mail the warranty registration card and have the installer fill in the installation data sheet in the back of the manual for warranty and future reference.

WESTPORT PARTS LIST

BEDFORD

PART #	DESCRIPTION	PART #	DESCRIPTION
WP-008	BURNER SWITCH	30-059	ARCH FILIGREE DOOR
WP-030	BLANK ORIFICE	30-065	GOTHIC FILIGREE DOOR
WP-031	THERMOCOUPLE	50-282	TOP
WP-032	IGNITOR ELECTRODE and WIRE	50-283	FRONT POSTS (R & L)
WP-035	PIEZO IGNITOR	50-284	REAR POSTS (R & L)
WP-036	16" IGNITOR CABLE	50-285	ASH SHELF
WP-040	THERMOPILE	50-286	SIDE (R & L)
WP-041	SIT NOVA 820 VALVE NG	50-287	FRONT
WP-042	SIT NOVA 820 VALVE LP	50-288	FRONT BOTTOM RAIL
WP-043	PILOT W/ELECTRODE NG	50-289	SIDE BOTTOM RAILS
WP-044	PILOT W/ELECTRODE LP	50-290	ALUMINUM INSERTS SET OF 4 (3 FOR TOP, 1 FOR ASH SHELF)
WP-062	18" FLEX LINE WITH 3/8 ELBOW		
WP-072	LOG SET W/EMBERS		
WP-073	EMBERS		
WP-074	ELECTRONIC IGNITION MODULE		
WP-087	RELIEF DOOR GASKET		
WP-089	WINDOW CHANNEL TAPE		
WP-090	1 PC. GLASS W/TAPE		
WP-092	PAINTED DOOR ONLY		
WP-099	BURNER COMPLETE		
WP-101	PILOT GASKET		
			<u>FORREST PAINT COLOR CODE FOR VENT PIPE</u>
		SB-	SATIN BLACK
		AW-	ANTIQUÉ WHITE 64EN7792
		DB-	DIAMOND BLACK 64E200
		PG-	PEARL GREY 64DN8880
		IR-	INFERNO RED 64EN7488
		WB-	WEDGEWOOD BLUE 64EN6701
		WG-	WESTPORT GREEN 64EN6943
	OPTIONAL BLOWER		
WP-001	CONVECTION BLOWER		
WP-002	HEYCO STRAIN RELIEF		
WP-003	FAN CONTROLLER W/KNOB		
WP-004	POWER CORD		
WP-014	120 CERAMIC FAN TEMP SENSOR		
WP-067	FAN CONTROLLER KNOB		
	CAST PARTS		
EG-WP-501	TOP COMPLETE (top, vent insert & grate)		<u>SPECIFY COLOUR</u>
EG-WP-502	TOP GRATE		
EG-WP-503	TOP VENT INSERT PIECE	SB-	SATIN BLACK
EG-WP-504	SIDE PANEL (LEFT)	AW-	ANTIQUÉ WHITE
EG-WP-505	SIDE PANEL (RIGHT)	DB-	DIAMOND BLACK
	FRONT COMPLETE (DOOR FRAME, LEFT AND	PG-	PEARL GREY
EG-WP-506	RIGHT DOOR, ASH LIP, 4 DOORS HINGE PINS	IR-	INFERNO RED
	AND DOOR KNOB	WB-	WEDGEWOOD BLUE
EG-WP-507	ASH LIP	WG-	WESTPORT GREEN
EG-WP-508	LEG (EACH)		
EG-WP-509	DOOR HINGE PIN (GOLD)		
EG-WP-510	DOOR HINGE PIN (SILVER)		
EG-WP-511	DOOR KNOB (GOLD)		
EG-WP-512	DOOR KNOB (SILVER)		

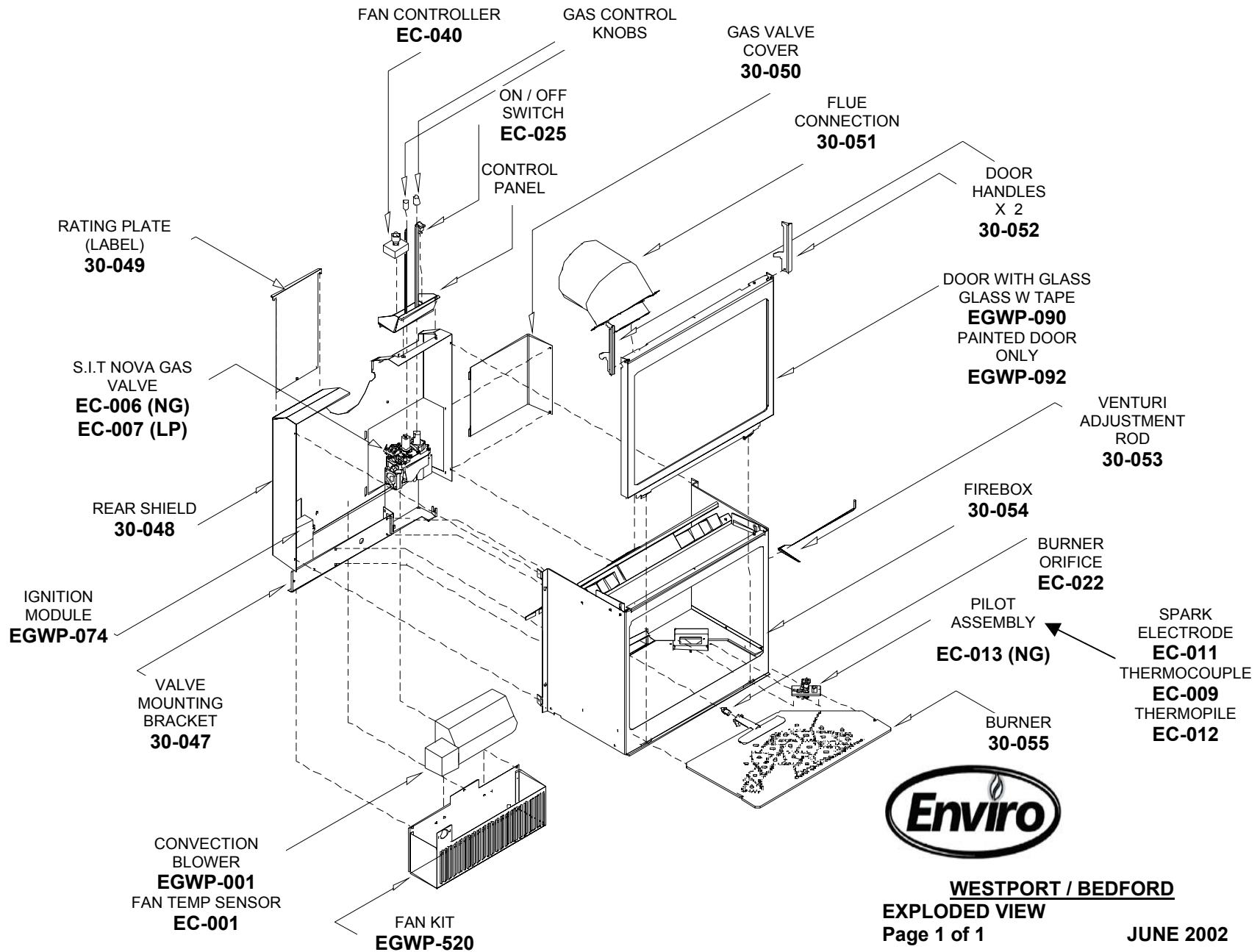

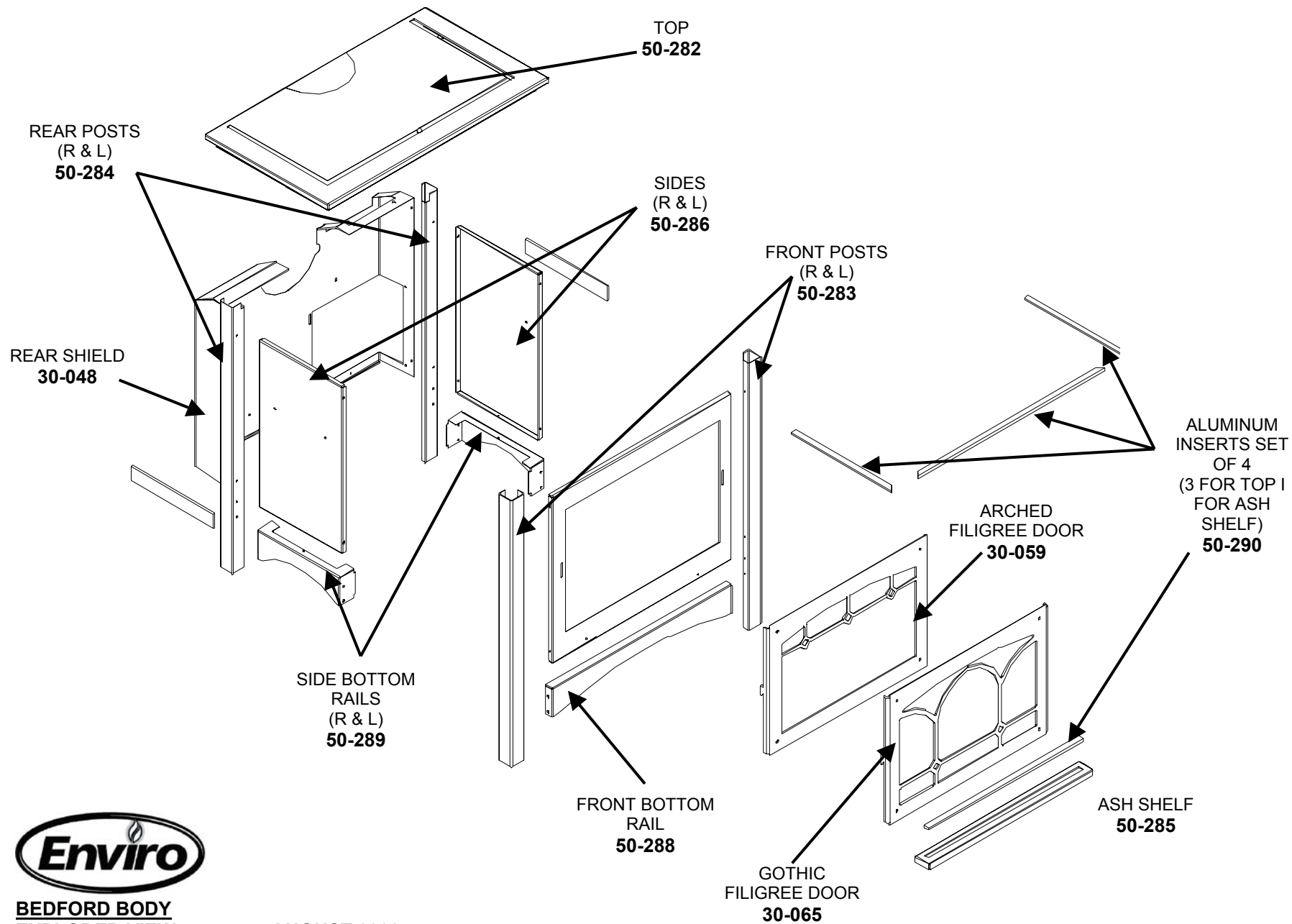

**BEDFORD BODY
EXPLODED VIEW**

AUGUST 2002

INSTALLATION DATA SHEET

The following information must be recorded by the installer for warranty purposes and future reference.

**Envirogas Model:
WESTPORT / BEDFORD DV**

Name of Owner: _____

Address: _____

Phone: _____

Name of Dealer: _____

Address: _____

Phone: _____

- Model : _____
- Serial Number: _____
- Date of Purchase:
_____/_____/_____
- Date of Installation:
_____/_____/_____
- ___ Natural Gas (Nat.), ___ Propane (LPG)
- Inlet Gas Supply Pressure: _____ in.w.c.

If the orifices were changed by the installer.

Main Burner Orifice; _____ # DMS

- Pilot Orifice # _____ or _____ in.Dia.

Installer's Signature

Name of Installer: _____

Address: _____

Phone : _____

WEB SITE ADDRESS (www.envirofire.biz)

02 08 29

MANUFACTURED BY:

SHERWOOD INDUSTRIES, 6782 OLDFIELD ROAD, SAANICHTON, B.C., CANADA V8M 2A3